

NEWS 2019

Poliform

Poliform

La pacatezza delle tonalità chiare, l'esplorazione di nuove sensazioni tattili, i dettagli che perfezionano il progetto e che, come un filo prezioso, legano un ambiente all'altro. Il racconto di Poliform al cinquantottesimo Salone Internazionale del Mobile di Milano inizia in una piazza, luogo di relazioni, e prosegue dentro spazi domestici, ispirati al vissuto intimo e personale di ciascuno di noi. Spazi veri, riletti da Poliform all'insegna dell'armonia tra estetica, architettura e materia.

The softness of the light colours, the exploration of new tactile sensations, the details that perfect the project and that, like a precious thread, bind an environment to another. The story of Poliform at the fifty-eighth Salone Internazionale del Mobile in Milan begins in a square – a place of relationships – and continues within domestic environments, inspired by the intimate and personal experience of each of us. Real spaces, reinterpreted by Poliform in the name of the harmony between style, architecture, and material.

COLLECTIONS

SALONE INTERNAZIONALE DEL MOBILE	7
WESTSIDE SOFA	37
WESTSIDE COFFEE TABLE	61
KAY LOUNGE ARMCHAIR	71
CODE DAY SYSTEM	79
CODE SIDEBORD	111
GENTLEMAN ARMCHAIR AND SOFA	123
NARA COFFEE TABLE	141
HENRY TABLE	147
MONDRIAN TABLE	157
HOME HOTEL TABLE	165
KELLY STORAGE UNITS	171
SENZAFINE WARDROBE AND WALK-IN CLOSET	177
UBIK WALK-IN CLOSET	231
CIRCLE MIRROR	241
TRATTO CARPET	247
FINISHINGS	254
FABRICS	265
LEATHERS	267



SALONE INTERNAZIONALE DEL MOBILE



Gli ambienti si susseguono in un unico dialogo stilistico. Dalla zona giorno alla zona notte, dagli spazi della convivialità a quelli dell'intimità, tutto è pensato per soddisfare con eleganza le esigenze dell'abitare contemporaneo.

The environments follow one another in a single stylistic dialogue. From the day area to the night area, from the spaces of conviviality to those of intimacy, everything is designed to elegantly satisfy the needs of contemporary living.







Divani componibili, tavoli dalle dimensioni generose e poltrone avvolgenti sono protagonisti della zona giorno. I prodotti, pur firmati da mani diverse, sono parte di un progetto di stile coordinato e coerente.

Modular sofas, generously sized tables, and enveloping armchairs are the stars of the day area. The products, although signed by different hands, are part of a coordinated and coherent style project.





Nella zona notte, armadi, cabine e complementi accolgono nuovi accessori e finiture, in un crescendo di sperimentazione stilistica, cromatica e tattile. I dettagli richiamano quelli della zona giorno, creando continuità tra le aree della casa.

In the night area, wardrobes, closets, and complements welcome new accessories and finishes, in a crescendo of stylistic, chromatic, and tactile experimentation. The details match those of the day area, creating continuity between the areas of the house.

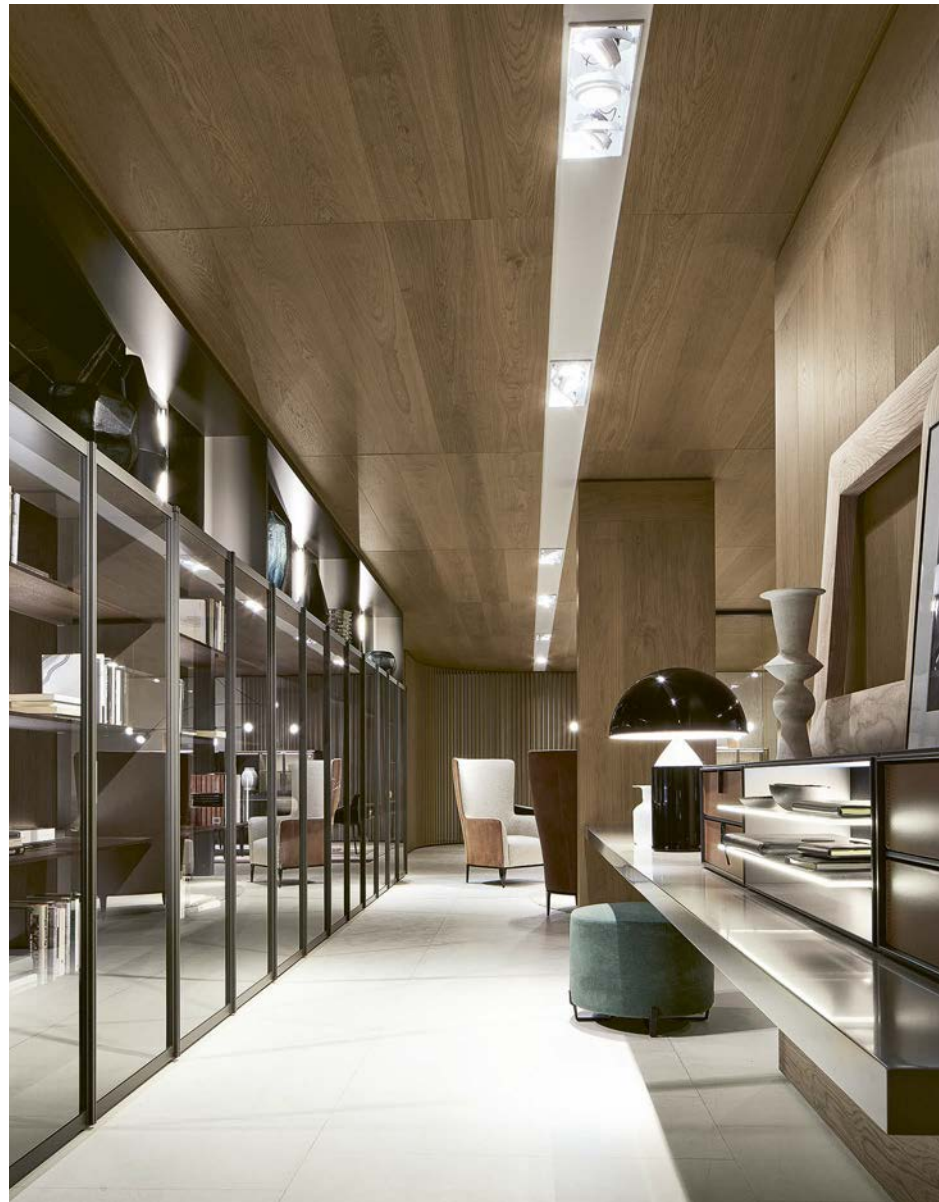



I toni della zona giorno sono prevalentemente chiari, dal pavimento in pietra alla boiserie in rovere naturale, dai tessuti color sabbia alle finiture metalliche champagne. Un cambiamento stilistico che è soprattutto sensoriale.

The tones of the day area are predominantly light, from the stone floor to the natural oak wall panelling, from the sand-coloured fabrics to the champagne metallic finishes. A stylistic change that is above all sensorial.





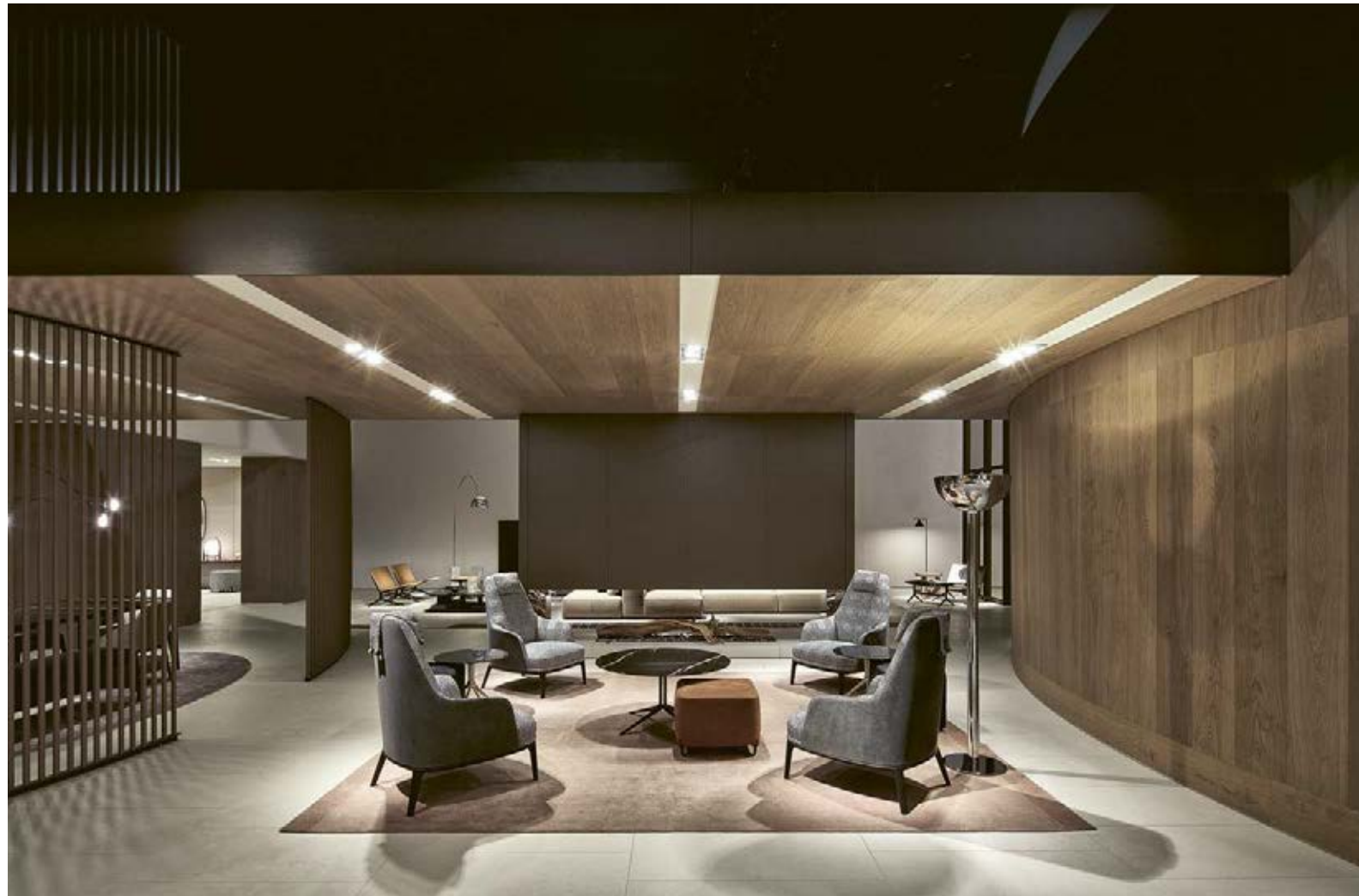

Forme sinuose e finiture preziose per il living e la zona pranzo. Le sedute hanno forme morbide e accoglienti, i piani di tavoli e tavolini sono in marmo: ogni dettaglio contribuisce a rendere unico e straordinario l'insieme.

Sinuous shapes and precious finishes for the living and dining areas. The seats have soft and welcoming shapes, the tops of tables and coffee tables are in marble: every detail contributes to making the whole unique and extraordinary.

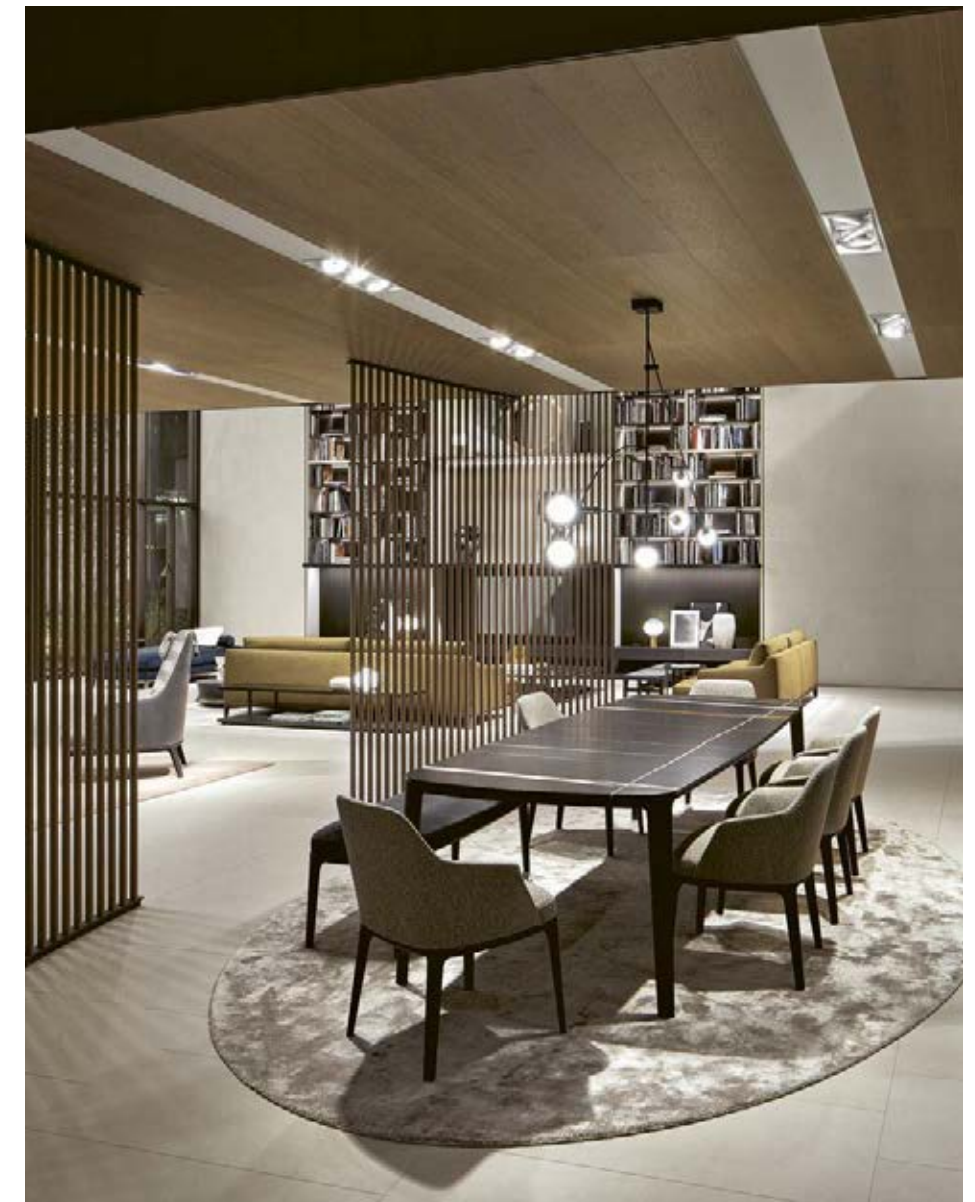



Le tonalità chiare arrivano nella zona notte, dove la boiserie e le ante degli armadi in tessuto lino chiaro sono abbinati al tappeto color crema. Anche i rumori sono attutiti in camera da letto, luogo di privacy e quiete.

The light shades reach the night area, where the wall panelling and doors of the wardrobes in fabric lino chiaro finish match with the cream-coloured rug. Even the noises are muffled in the bedroom, a place of privacy and quietness.



Le finestre si affacciano sulla piazza illuminata e sui giardini, offrendo a chi è all'interno uno scorcio sugli esterni che rafforza l'idea di casa e la sensazione di poter godere di una libertà senza limiti.

The windows overlook the illuminated square and the gardens, offering those who are inside a glimpse of the exterior, which reinforces the idea of home and the feeling of being able to enjoy unlimited freedom.



Poliform presenta i nuovi prodotti, progetti originali e restyling che traducono un'idea di stile in un qui e ora. Jean-Marie Massaud ridisegna la zona giorno con il nuovo sistema di divani e tavolini Westside, la poltrona Kay Lounge, i tavoli da pranzo Mondrian e Home Hotel, il tavolino in legno massello Nara. Il living si arricchisce anche della nuova collezione di sedute Gentleman, firmata da Marcel Wanders. Emmanuel Gallina progetta il tavolo Henry per la sala da pranzo e reinterpreta alcuni pezzi della collezione Kelly nella zona notte. Poliform ragiona sui sistemi: è nuovo il day system Code, versatile e funzionale come la madia omonima, mentre agli armadi Senzafine e Ubik si aggiungono inedite soluzioni estetiche, finiture e accessori.

Poliform presents the new products, original projects and restyling that translate an idea of style into here and now. Jean-Marie Massaud redesigns the day area with the new sofas and coffee tables system Westside, the armchair Kay Lounge, the dining tables Mondrian and Home Hotel, the solid wood coffee table Nara. The living area is also joined by the new Gentleman seating collection, designed by Marcel Wanders. Emmanuel Gallina designs the Henry table for the dining room, and reinterprets some pieces from the Kelly collection in the night area. Poliform works on the systems: the new day system Code, versatile and functional like the homonymous sideboard, while the wardrobes Senzafine and Ubik are joined by brand-new aesthetic solutions, finishes, and accessories.

WESTSIDE SOFA

Westside è un sistema multifunzionale che riscrive con eleganza l'esperienza della zona living. I moduli imbottiti si affiancano tra loro per creare le più diverse configurazioni – dall'isola bifacciale al classico divano angolare – mentre gli elementi come la chaise longue ergonomica, lo schienale mobile e i tavolini ne arricchiscono la funzionalità. Un archetipo di convivialità da vivere con la massima libertà.

Westside is a multifunctional system that elegantly rewrites the experience of the living area. The padded modules come together to create the most diverse configurations – from the two-face island to the classic corner sofa – while the elements such as the ergonomic chaise longue, the movable backrest, and the coffee tables enrich its functionality. An archetype of conviviality to be experienced with maximum freedom.

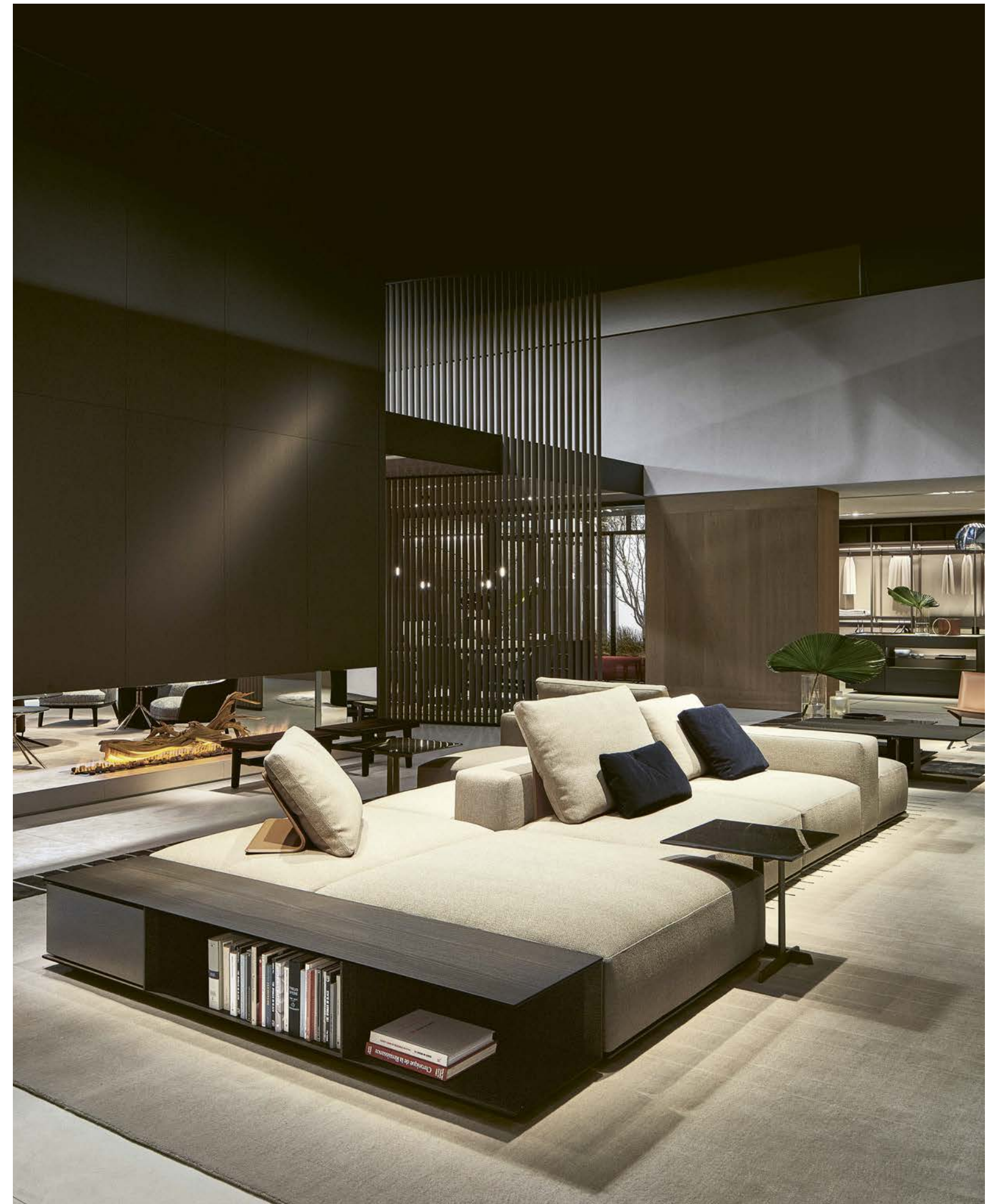





Qui e nelle pagine precedenti: divano Westside, rivestimento sfoderabile in tessuto Arcadia 02 sabbia, cuscini in tessuto Tebe 08 notte. Poggiatesta e schienale mobile in cuoio 26 invecchiato. Retro divano in olmo nero con cassetto laccato semilucido 49 moka. Basamento brown nickel opaco. Tavolini Westside, quadrato con struttura in olmo nero e piano superiore in marmo sahara noir lucido finitura poliesterre, rettangolare con struttura in champagne satinato e piano in olmo nero, quadrati piccoli con struttura in champagne satinato e piano in marmo sahara noir lucido finitura poliesterre. Sotto: dettaglio dello schienale mobile in cuoio 26 invecchiato.

Here and on the previous pages: Westside sofa, removable cover in Arcadia fabric 02 sabbia, cushions in Tebe fabric 08 notte. Headrest and movable backrest in hide 26 invecchiato. Behind sofa coffee table in black elm with semi-glossy lacquered drawer 49 moka. Mat brown nickel base. Westside coffee tables, square with black elm structure and upper top in glossy sahara noir marble with polyester finish, rectangular with brushed champagne structure and black elm top, small squares with brushed champagne structure and top in glossy sahara noir marble with polyester finish. Below: detail of the movable backrest in hide 26 invecchiato.

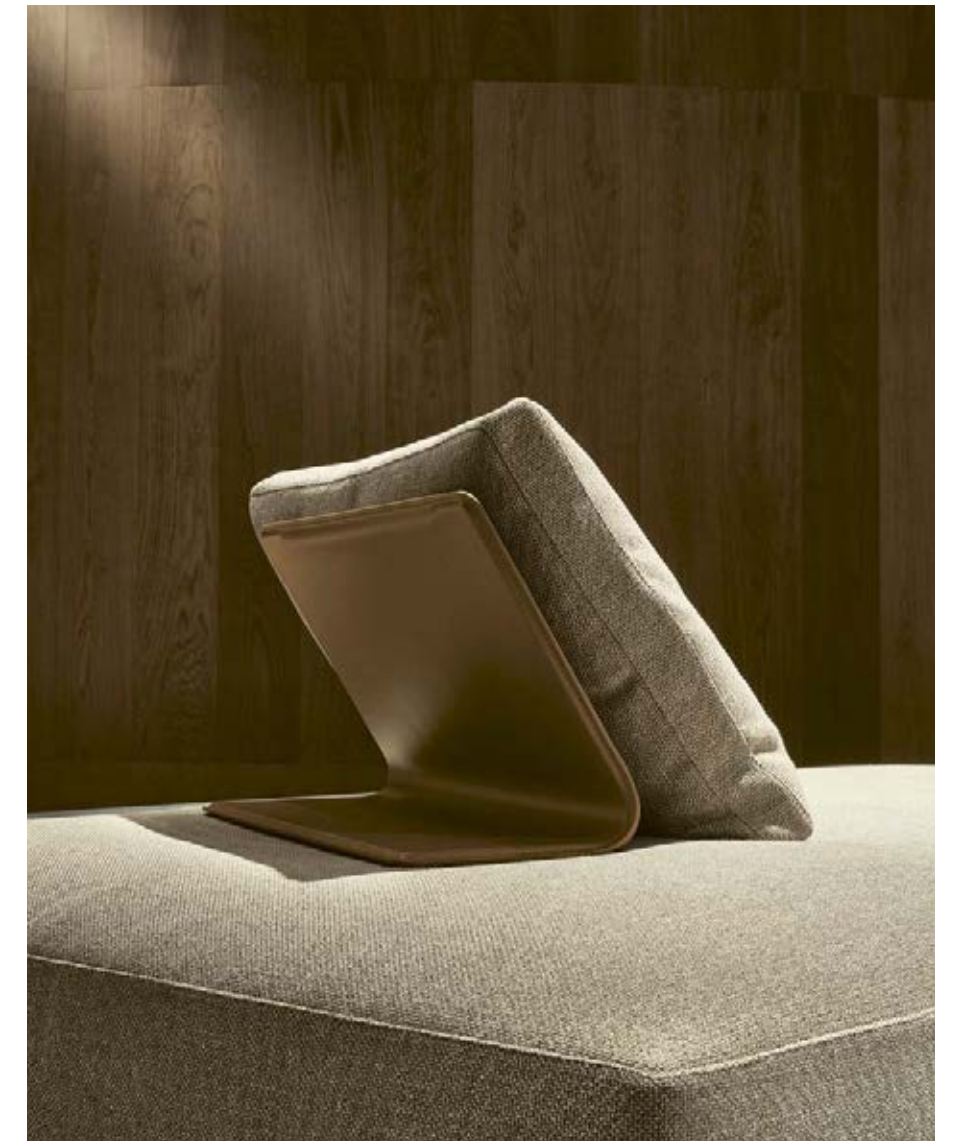





Qui, nella pagina precedente e nella successiva: divano Westside, rivestimento sfoderabile in tessuto Arcadia 06 tortora, cuscini in tessuto Sendai 03 fango. Basamento brown nickel opaco. Pouf Westside, rivestimento sfoderabile in pelle Silk 10 terracotta e basamento brown nickel opaco. Tavolini Westside, quadrato con struttura in olmo nero e cassetti laccato metallico 24 ottone, rettangolare con struttura in brown nickel satinato e piano in marmo zecevo levigato, quadrati piccoli con struttura in brown nickel satinato e piano in olmo nero, quadrato piccolo con struttura in brown nickel satinato e piano in marmo zecevo levigato. Sotto: dettaglio dello schienale con mensola, esterno in cuoio 02 nero, interno brown nickel opaco.

Here, on the previous page and on the next one: Westside sofa, removable cover in Arcadia fabric 06 tortora, cushions in Sendai fabric 03 fango. Mat brown nickel base. Westside footstool, removable cover in Silk leather 10 terracotta and mat brown nickel base. Westside coffee tables, square with structure in black elm and drawers in metal lacquer 24 ottone, rectangular with structure in brushed brown nickel and top in mat zecevo marble, small squares with structure in brushed brown nickel and top in black elm, small square with structure in brushed brown nickel and zecevo mat marble top. Below: detail of the backrest with shelf, exterior in hide 02 nero, mat brown nickel interior.





Qui e nella pagina successiva: divano Westside, rivestimento sfoderabile in tessuto Antea 04 canapa, cuscini in tessuto Lero 01 ecru. Schienale mobile in cuoio 29 tortora. Basamento brown nickel opaco. Pouf Westside, rivestimento sfoderabile in pelle Nabuk 05 grafite e basamento brown nickel opaco. Tavolini Westside, quadrato con struttura in olmo nero e piano in marmo zecevo levigato, rettangolare con struttura in olmo nero e piano in marmo zecevo levigato, quadrati piccoli con struttura in brown nickel satinato e piano in olmo nero. Sotto: dettaglio del tavolino retro divano con struttura in olmo nero e cassetti in laccato semilucido 89 roccia. A destra: dettaglio della chaise longue con retro schienale e del retro divano con mensola, esterno in cuoio 29 tortora, interno brown nickel opaco.

Here and on the next page: Westside sofa, removable cover in Antea fabric 04 canapa, cushions in Lero fabric 01 ecru. Movable backrest in hide 29 tortora. Mat brown nickel base. Westside footstool, removable cover in Nabuk leather 05 grafite and mat brown nickel base. Westside coffee tables, square with black elm structure and top in zecevo mat marble, rectangular with black elm structure and zecevo mat marble top, small squares with brushed brown nickel structure and black elm top. Below: detail of the behind sofa coffee table with structure in black elm and drawers in semi-glossy lacquered 89 roccia. On the right: detail of the chaise longue with backrest and the behind sofa element with shelf, exterior in hide 29 tortora, mat brown nickel interior.





WESTSIDE

Design Jean-Marie Massaud

Dati tecnici

Struttura in legno e derivati. Cuscino schienale e seduta in poliuretano espanso a quote differenziate, rullo in poliuretano espanso, prerivestimento in tela cotone e piuma. Cuscini opzionali in tela cotone e piuma.

Bracciolo Slim, schienale chaise longue e retro divano con struttura in alluminio finitura brown nickel opaco e rivestito all'esterno in cuoio colori. Poggiatesta e schienale mobile con struttura in metallo rivestito in cuoio colori.

Basamento in brown nickel opaco.

Rivestimento sfoderabile in tessuto o pelle.

Versione in tessuto con costina e versione in pelle con cucitura doppia e giunta verticale su tutti gli angoli.

Technical data

Structure in wood and wood-based products. Backrest cushion and seat in differentiated-density polyurethane foam, roll cushion in expanded polyurethane, pre-cover in cotton canvas and feather. Optional cushions in cotton canvas and feather.

Slim arm, chaise longue backrest and sofa rear with aluminium structure in mat brown nickel finish and covered outside in hide in the available colours. Headrest and movable backrest with metal structure covered in hide in the available colours.

Base in mat brown nickel.

Removable cover in fabric or leather.

Fabric version with piping and leather version with double stitching and vertical joint on all corners.

Regola compositiva Composition rule

Per la progettazione di una composizione bifacciale partire da una combinazione lineare, successivamente accostare gli elementi posteriormente e/o lateralmente.

To design a double-sided composition always start from a linear combination, then add the units to the back or to the side of the sofa.

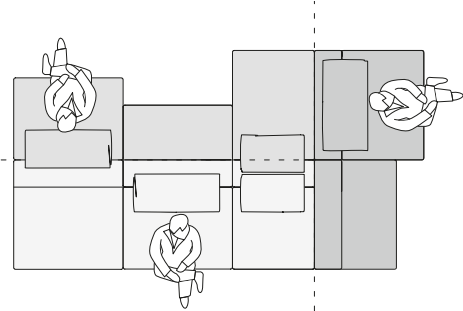

Esempi di accostamenti bifacciali Examples of double-sided solutions

Il bracciolo non può avere funzione di schienale (1). Allineamento schienali possibile solamente con sedute sullo stesso lato (2).

The arm cannot be used as a backrest (1). The backrests are aligned only if seat cushions are on the same side (2).

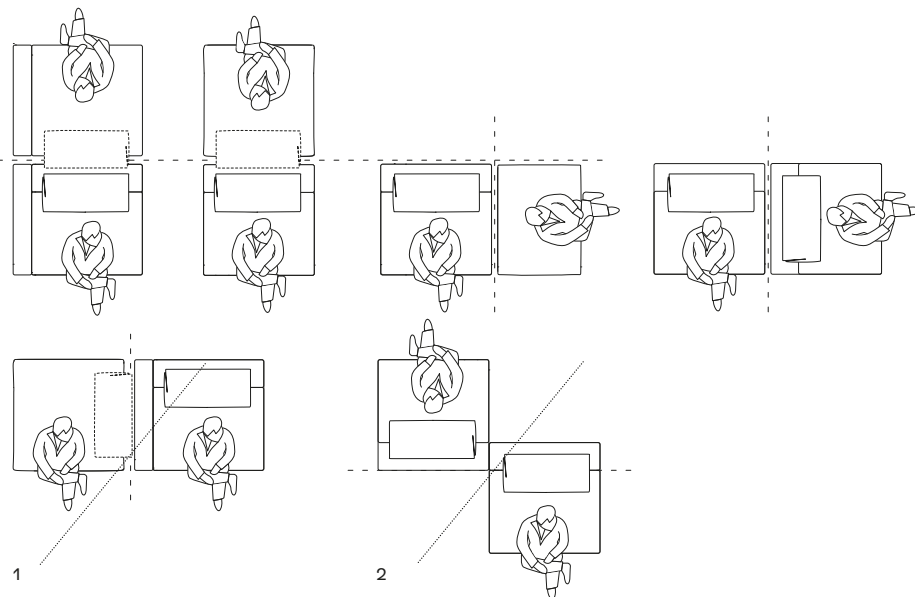

Tipologie bracciolo Arm types



bracciolo
arm



bracciolo Slim
Slim arm



senza bracciolo
without arm

Tipologie cuscino Cushion types



cuscino schienale
backrest cushion



cuscino schienale con rullo
backrest cushion with roll cushion



cuscino schienale con poggiatesta
backrest cushion with headrest

Tipologie cuscino versione bifacciale Cushion types for double-sided version



opzione 1
option 1



opzione 2
option 2



opzione 3
option 3



opzione 4
option 4

WESTSIDE
Design Jean-Marie Massaud

**Terminale sx-dx
Lt-rt end unit**

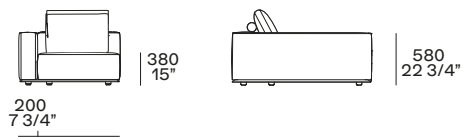

**Terminale sx-dx con bracciolo Slim
Lt-rt end unit with Slim arm**

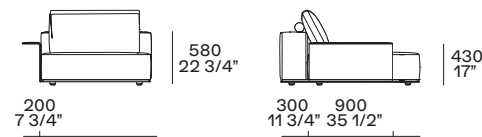

**Centrale
Central unit**

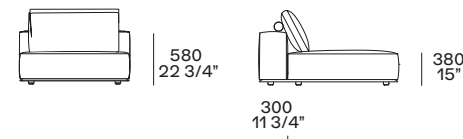

**Centrale con schienale con mensola
Central unit with backrest with shelf**

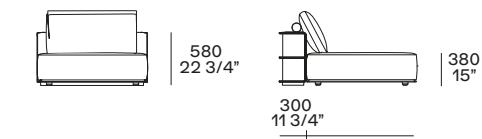

**Chaise longue
Chaise longue**

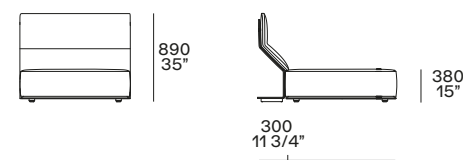

**Chaise longue sx-dx con bracciolo Slim
Lt-rt chaise longue with Slim arm**

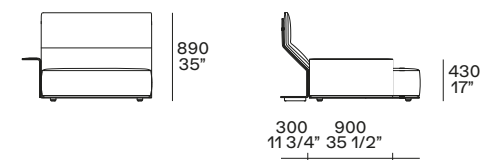

**Poggiatesta
Headrest**

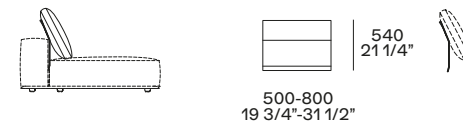

Non utilizzabile su pouf, chaise longue, elemento con mensola.
Not to be used on pouf, chaise longue, element with shelf.

**Schienale mobile
Movable backrest**

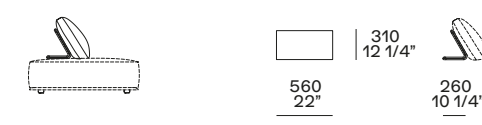

Utilizzabile solo su pouf.
To be used only on pouf.

**Cuscini schienale con o senza rullo Ø 90
Backrest cushions with or without roll cushion Ø 90**

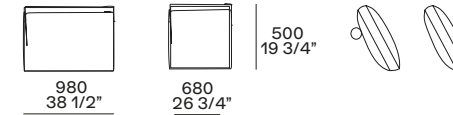

Larghezza 680-980 da abbinare in base alla larghezza degli schienali.
Width 680-980 to match according to the width of the backrests.

**Cuscini opzionali comfort
Optional comfort cushions**



**Cuscino opzionale a fascia
Optional band cushion**

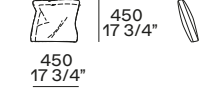

**Elemento retro divano con mensola
Behind sofa element with shelf**

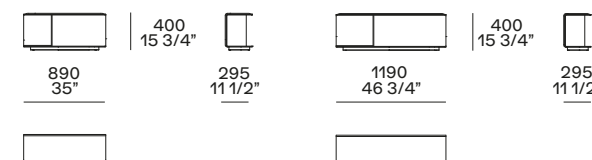

**Elemento retro divano con vano a giorno
Behind sofa element with open compartment**

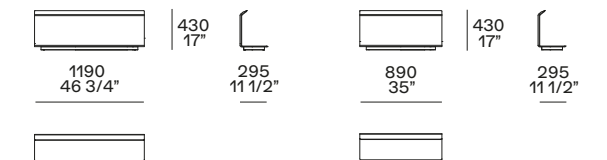

**Tavolino retro divano
Behind sofa coffee table**

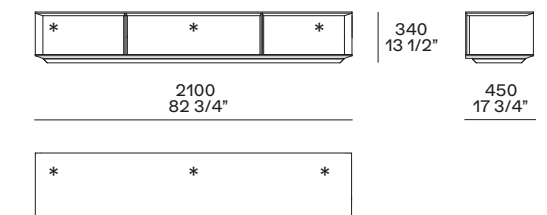
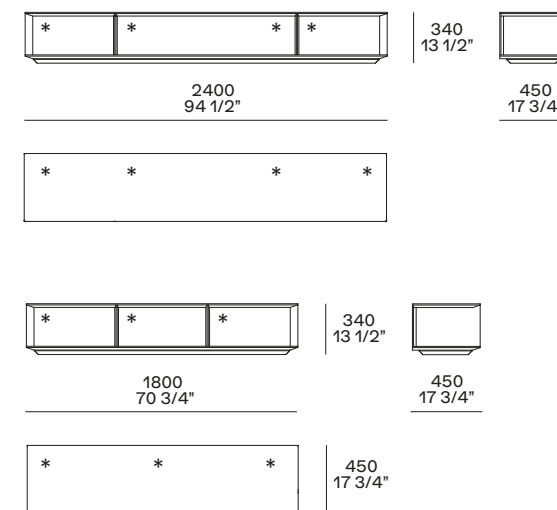

**Cassetto opzionale *
Optional drawer ***

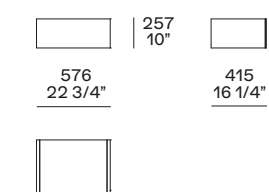

WESTSIDE
Design Jean-Marie Massaud

**Terminale sx-dx
Lt-rt end unit**

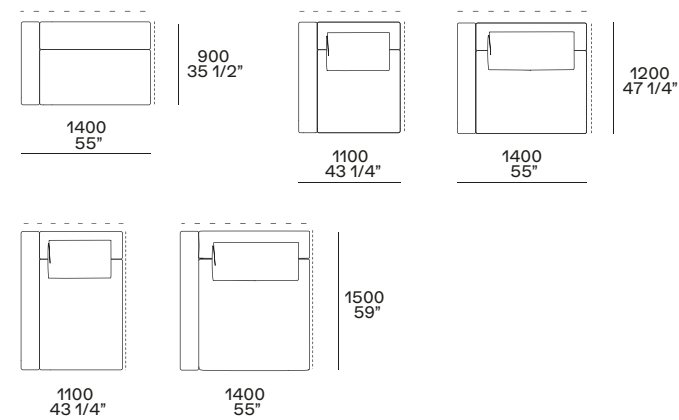

**Terminale isola sx-dx
Lt-rt island end unit**

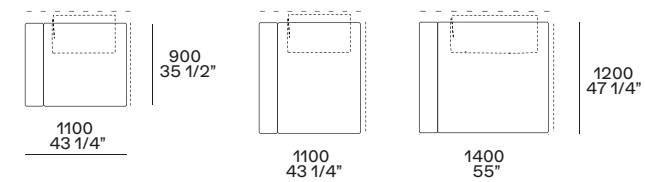

Nelle composizioni bifacciali i cuscini schienale sono appoggiati allo schienale dell'elemento retrostante.
In the double-sided compositions the backrest cushions rest on the backrest of the element behind.

**Centrale
Central unit**

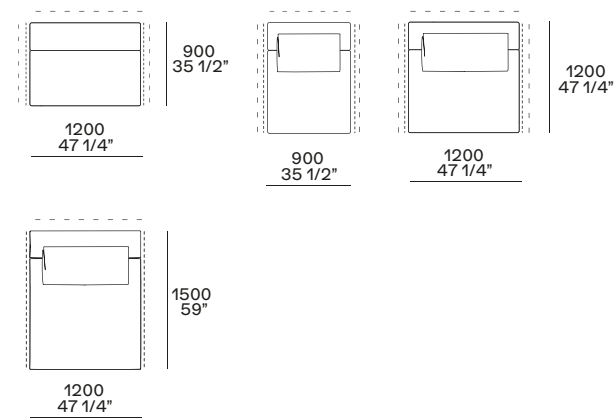

**Centrale con schienale con mensola
Central unit with backrest with shelf**

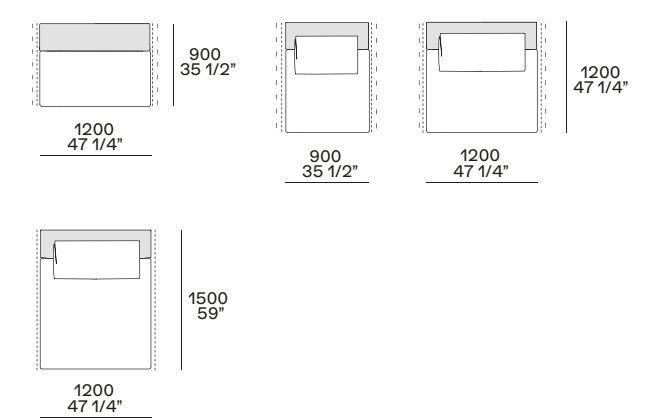

**Terminale sx-dx con bracciolo Slim
Lt-rt end unit with Slim arm**

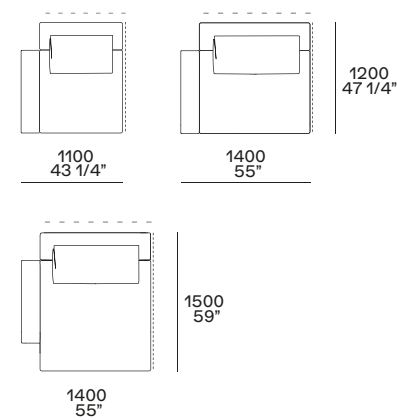

**Pouf
Pouf**

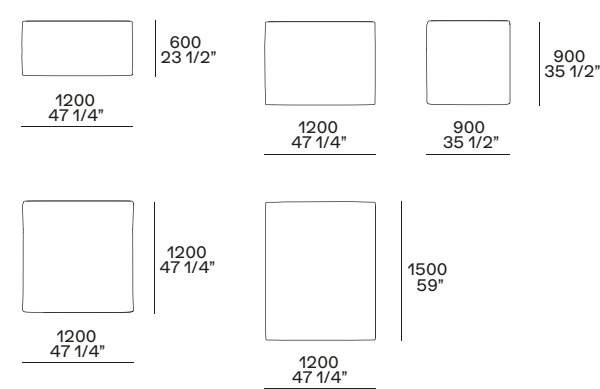

Uso terminale, centrale, angolare e bifacciale su tutti i lati tranne che per il modulo 1200x600 componibile in bifacciale solo su lato lungo.
Terminal, central, corner and double-sided use on all sides except for the 1200x600 module, which is double-sided modular only on the long side.

**Chaise longue
Chaise longue**

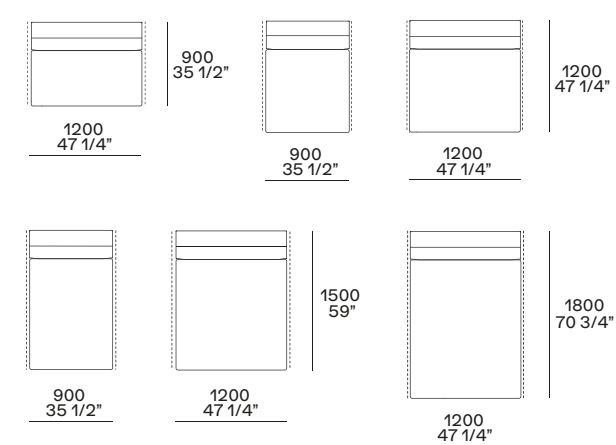

**Chaise longue sx-dx con bracciolo Slim
Lt-rt chaise longue with Slim arm**

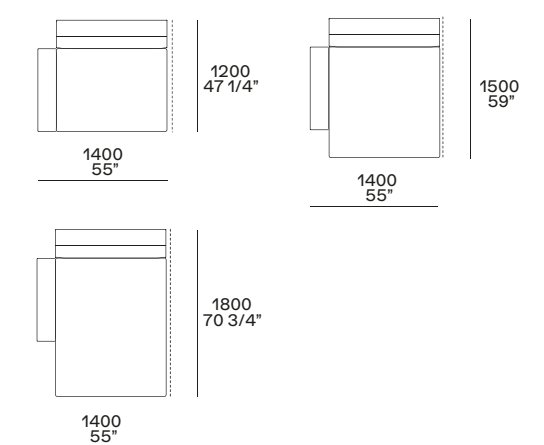

**Angolo sx-dx
Lt-rt corner**

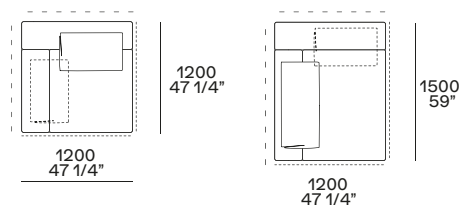

componibilità bifacciale
double-sided modularity

componibilità lineare
linear modularity



WESTSIDE COFFEE TABLE



Un raffinato equilibrio tra materiali e forme contraddistingue i tavolini della collezione Westside, che completano l'omonimo sistema di divani. Tre le versioni, disponibili in diverse finiture: il tavolino con cassetto o vano a giorno, il tavolino con base a incrocio in metallo e quello da accostare al divano.

A refined balance between materials and shapes characterizes the coffee tables of the Westside collection, which complete the homonymous system of sofas. There are three versions, available in different finishes: the coffee table with drawer or open compartment, the coffee table with crossed metal base, and the one to place next to the sofa.







Nella pagina introduttiva e a sinistra: tavolini Westside, quadrato con struttura in olmo nero e cassetti laccato metallico 24 ottone, rettangolare con struttura in brown nickel satinato e piano in marmo zecevo levigato, quadrati piccoli con struttura in brown nickel satinato e piano in olmo nero. Nella precedente: quadrato con struttura in olmo nero e piano superiore in marmo sahara noir lucido finitura poliester, rettangolare con struttura in champagne satinato e piano in olmo nero. Sotto: tavolino quadrato piccolo con struttura in brown nickel satinato e piano in marmo zecevo levigato.

On the introductory page and on the left: Westside small tables, square with black elm structure and metal lacquer drawers 24 ottone, rectangular with brushed brown nickel structure and zecevo mat marble top, small squares with brushed brown nickel structure and black elm top. On the previous one: square with structure in black elm and upper top in glossy sahara noir marble with polyester finish, rectangular with brushed champagne structure and black elm top. Below: small square coffee table with brushed brown nickel structure and zecevo mat marble top.

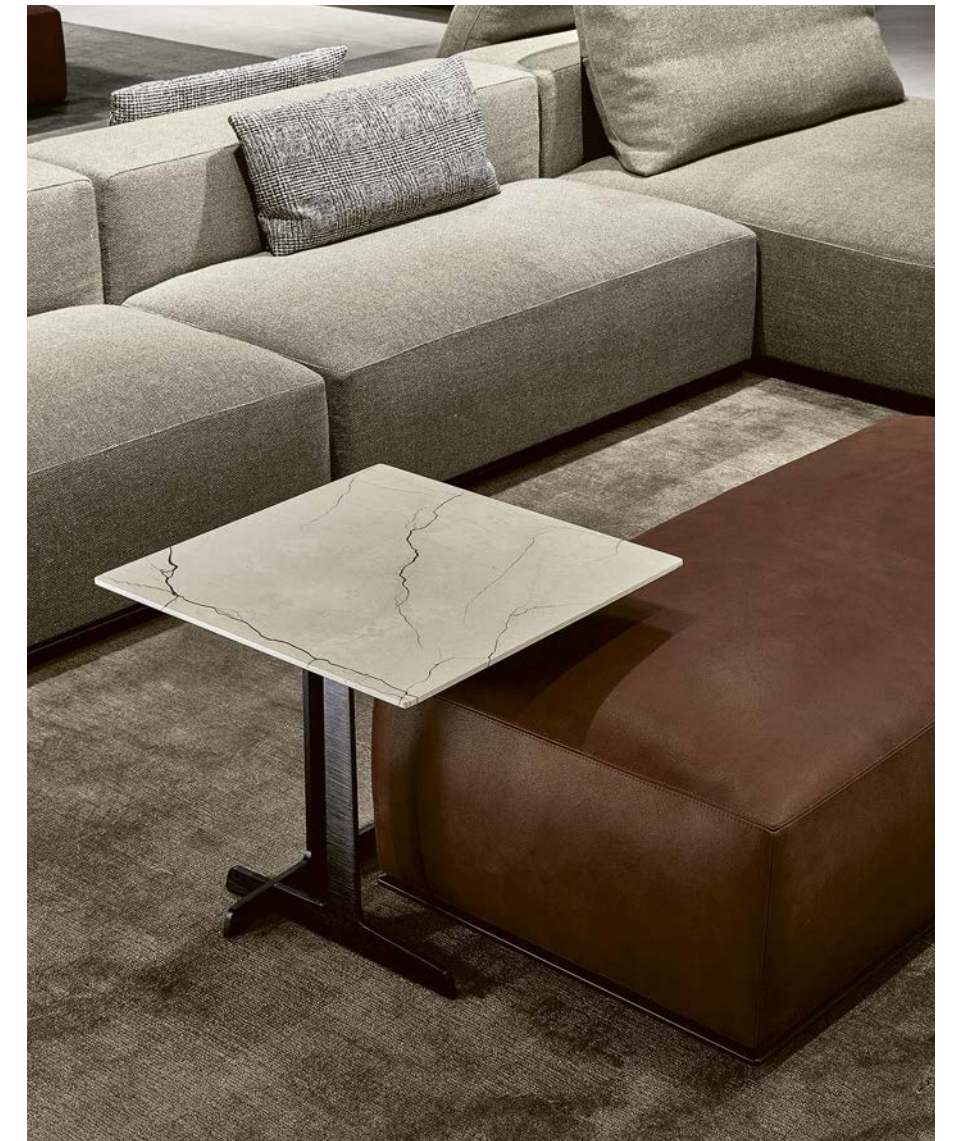

WESTSIDE

Design Jean-Marie Massaud

Dati tecnici tavolini

Struttura in olmo nero. Piano in olmo nero, sei marmi levigati e sette lucidi.
Cassetto opzionale per vani a giorno, in laccato opaco colori, laccato metallico 24 ottone o 23 bronzo.

tavolini metallo

Struttura in metallo brown nickel satinato o champagne satinato. Piano in olmo nero, sei marmi levigati e sette lucidi.

Technical data coffee table

Black elm structure. Black elm top, six mat marbles and seven glossy marbles.
Optional drawer for open compartments, in mat lacquered colours, metal lacquer 24 ottone or 23 bronzo.

metal coffee table

Brown nickel brushed or champagne brushed metal structure. Black elm top, six mat marbles and seven glossy marbles.

Tavolini Coffee table

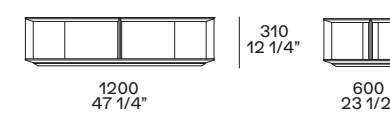
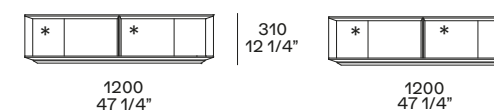

Tavolini metallo Metal coffee table

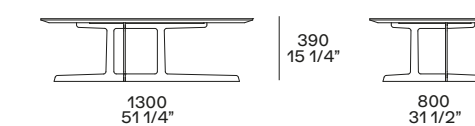
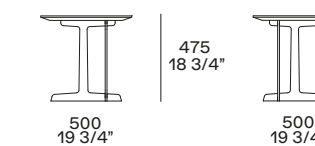

Cassetto opzionale * Optional drawer *

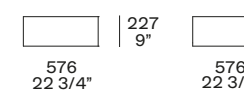

Disponibile solo per tavolino 1200x1200 con piano in olmo nero.

Available only for coffee table 1200x1200 in the version with black elm top.





KAY LOUNGE

Elegante, leggera ed essenziale, Kay Lounge è una poltrona dall'innata modernità. La struttura è in metallo, mentre la seduta è disponibile in pelle o cuoio. Da sola o in coppia, con il caratteristico poggiatesta, Kay Lounge è una poltrona che si fa notare in ogni contesto, dal più classico al più contemporaneo.

Elegant, light, and minimalistic, Kay Lounge is an armchair with an innate modernity. The structure is in metal, while the seat is available in leather or hide. Alone or paired, with the characteristic footrest, Kay Lounge is an armchair that stands out in every context, from the most classic to the most contemporary.







Nella pagina introduttiva: poltrona e pouf Kay Lounge, rivestimento non sfoderabile in pelle Hairy bianco/nero e struttura in cromo satinato. Sopra e nella pagina precedente: poltrona e pouf Kay Lounge, rivestimento non sfoderabile in pelle Silk 12 senape e struttura in cromo satinato.

On the introductory page: Kay Lounge armchair and footstool, non-removable cover in white/black Hairy leather and structure in brushed chrome. Above and on the previous page: Kay Lounge armchair and footstool, non-removable cover in Silk leather 12 senape and structure in brushed chrome.

KAY LOUNGE

Design Jean-Marie Massaud

Dati tecnici

Seduta e schienale in poliuretano flessibile stampato. Rivestimento non sfoderabile in pelle o cuoio colori. Struttura in metallo, finitura cromo satinato, champagne opaco o brown nickel satinato.

Technical data

Seat and backrest in flexible moulded polyurethane. Non-removable cover in leather, or hide in the available colours. Structure in metal, finish brushed chrome, mat champagne or brushed brown nickel.

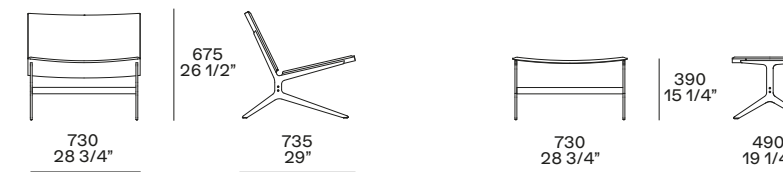



CODE DAY SYSTEM

Code è un sistema versatile progettato per la zona giorno ma ideale anche nella zona notte. Contenitori sospesi, vetrine, mensole e desk uniscono funzionalità ed estetica suggerendo diverse configurazioni, dalla più essenziale alla più tradizionale.

Code is a versatile system designed for the day area but also ideal for the night area. Suspended containers, display cases, shelves, and desks combine functionality and style suggesting different configurations, from the most minimalistic to the most traditional.







Qui e nelle pagine precedenti: sistema Code con boiserie in laccato opaco 35 canapa e in tessuto lino chiaro, profili champagne opaco. Contenitori sospesi retroilluminati, cassetti laccato metallico 24 ottone con fondo in tecnopelle 06 nocciola, top in marmo zecevo levigato. Mensole retroilluminate in laccato metallico 24 ottone, mensolone sospeso retroilluminato in olmo nero. In questa pagina: dettagli della canalina retroilluminata in olmo nero con profili champagne opaco, a sinistra attrezzata con carica a induzione per cellulari, sotto con passacavi e coperchio di chiusura finitura carbone opaco.

Here and on the previous pages: Code system with wall panelling in mat lacquered 35 canapa and in fabric lino chiaro, mat champagne profiles. Backlit suspended containers, drawers in metal lacquer 24 ottone with bottom in techno leather 06 nocciola, top in zecevo mat marble. Backlit shelves in metal lacquer 24 ottone, backlit suspended big shelf in black elm. On this page: details of the backlit cable raceway in black elm with mat champagne profiles, on the left equipped with induction charge for mobile phones, below with built-in cable passage channel and cover in mat carbone finish.



In questa pagina: dettaglio del sistema Code, composizione con boiserie in laccato opaco 35 canapa e in tessuto lino chiaro, profili champagne opaco. Contenitori sospesi retroilluminati, cassetti laccato metallico 24 ottone con fondo in tecnopelle 06 nocciola, top in marmo zecevo levigato. Mensole retroilluminate in laccato metallico 24 ottone, mensolone sospeso retroilluminato in olmo nero.

On this page: detail of the Code system, composition with wall panelling in mat lacquered 35 canapa and in fabric lino chiaro, mat champagne profiles. Backlit suspended containers, drawers in metal lacquer 24 ottone with bottom in techno leather 06 nocciola, top in zecevo mat marble. Backlit shelves in metal lacquer 24 ottone, backlit suspended big shelf in black elm.







Qui, nella pagina precedente e nella successiva: sistema Code, composizione retroilluminata, portale tv con schienale in tessuto lino chiaro, contenitori sospesi con frontali a ribalta in laccato metallico 23 bronzo e top in marmo zecevo levigato. Contenitori vetrina con ante in vetro trasparente riflettente 5000, profili ardesia opaco, struttura interna in olmo nero, schienali in tessuto lino chiaro, frontale cassette in laccato metallico 23 bronzo, ripiani in vetro trasparente riflettente 5000. Contenitori con ante e struttura interna in olmo nero, schienali in tessuto lino chiaro, ripiani in vetro trasparente riflettente 5000. Vani a giorno con struttura interna in laccato metallico 23 bronzo e schienali in olmo nero. Top e fianchi in olmo nero. A sinistra: dettaglio dei contenitori con ante in vetro trasparente riflettente 5000 e profili ardesia opaco. Sotto: dettaglio della maniglia ardesia opaco.

Here, on the previous and next page: Code system, backlit composition, TV portal with backrest in fabric lino chiaro, suspended containers with flap fronts in metal lacquer 23 bronzo and top in zecevo mat marble. Display cabinets with doors in reflective transparent glass 5000, mat ardesia profiles, internal structure in black elm, back panels in fabric lino chiaro, drawer fronts in metal lacquer 23 bronzo, shelves in reflective transparent glass 5000. Containers with doors and internal structure in black elm, back panels in fabric lino chiaro, shelves in reflective transparent glass 5000. Open compartments with internal structure in metal lacquer 23 bronzo and back panels in black elm. Top and sides in black elm. On the left: detail of the storage units with doors in reflective transparent glass 5000 and mat ardesia profiles. Below: detail of the mat ardesia handle.





Qui e nella pagina successiva: sistema Code, mensolone sospeso retroilluminato in laccato semilucido 48 visone. Contenitori sospesi retroilluminati con top in marmo zecevo levigato, cassetti e ribalte in noce gold, interni in nobilitato ardesia, fondo cassetti in tecnopelle 06 nocciola.

Here and on the next page: Code system, backlit suspended big shelf in semi-glossy lacquered 48 visone. Backlit suspended storage units with top in zecevo mat marble, drawers and flap doors in walnut gold, interior in ardesia melamine, drawers' bottoms in techno leather 06 nocciola.





In questa pagina: sistema Code, mensolone sospeso retroilluminato in noce gold. Contenitori sospesi retroilluminati con top e cassetti in laccato semilucido 48 visone, interni in nobilitato ardesia, fondo in tecnopelle 06 nocciola.

On this page: Code system, backlit suspended big shelf in walnut gold. Backlit suspended storage units with top and drawers in semi-glossy lacquered 48 visone, interior in ardesia melamine, bottom in techno leather 06 nocciola.







In questa pagina: sistema Code, mensolone sospeso retroilluminato in laccato lucido 87 granata. Nella pagina precedente: mensola retroilluminata in laccato metallico 24 ottone, contenitore sospeso retroilluminato con top in marmo zecevo levigato, cassetto in laccato metallico 24 ottone con interno in nobilitato ardesia e fondo in tecnopelle 06 nocciola, vano a giorno in laccato opaco 49 moka. Contenitori sospesi retroilluminati con top in marmo zecevo levigato, cassetti in noce gold con interni in nobilitato ardesia e fondo in tecnopelle 06 nocciola, vani a giorno in laccato opaco 77 champagne.

On this page: Code system, backlit suspended big shelf in glossy lacquered 87 granata. On the previous page: backlit shelf in metal lacquer 24 ottone, backlit suspended storage unit with zecevo mat marble top, drawer in metal lacquer 24 ottone with interior in ardesia melamine and bottom in techno leather 06 nocciola, open compartment in mat lacquered 49 moka. Backlit suspended storage units with zecevo mat marble top, drawers in walnut gold with interiors in ardesia melamine and bottom in techno leather 06 nocciola, open compartments in mat lacquered 77 champagne.

CODE DAY SYSTEM

Design R&D Poliform

Dati tecnici

Programma componibile per la zona giorno e notte, basato sul libero accostamento di un'ampia varietà di elementi a terra e a parete, a cui si integrano contenitori a giorno. Per le finiture disponibili vedere pagine dedicate.

- 1 Boiserie
- 2 Mensole
- 3 Contenitori bassi
- 4 Contenitori alti
- 5 Pensili
- 6 Bacheche
- 7 Vani a giorno
- 8 Portali TV
- 9 Mensoloni sospesi

Technical data

Modular program for the day and night area, based on the free combination of a wide variety of floor and wall elements, complemented by open storage units. For the available finishes see the dedicated pages.

- 1 Wall panelling
- 2 Shelves
- 3 Low storage units
- 4 Tall storage units
- 5 Hanging storage units
- 6 Open display cases
- 7 Open storage units
- 8 TV-portals
- 9 Suspended thick shelves

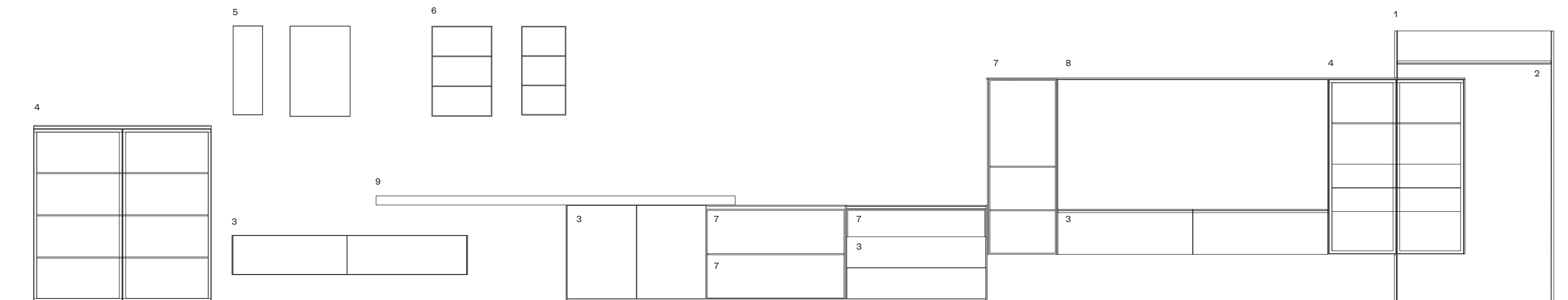

CODE DAY SYSTEM

Design R&D Poliform

Boiserie sp 30 Wall panelling th 1 1/4"

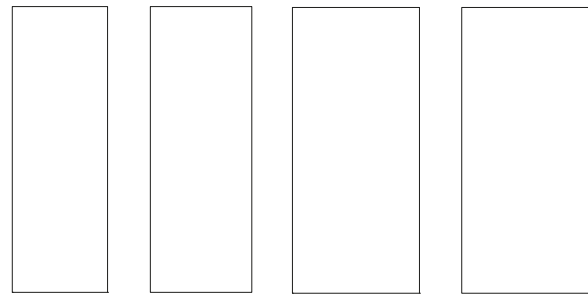

900
35 1/2"
960
37 3/4"
1200
47 1/4"
1260
49 1/2"

Laccate o essenza.
In lacquer or wood.



Profili laterali 4 mm.
Per boiserie h minore di 1900 sono previsti profili superiori.
Lateral profiles 5/32".
For wall panelling lower than 74 3/4" upper closing profiles are foreseen.

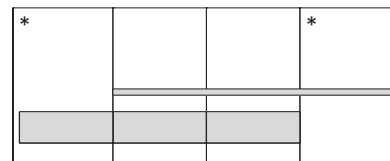

960
37 3/4"
900
35 1/2"
900
35 1/2"
960
37 3/4"

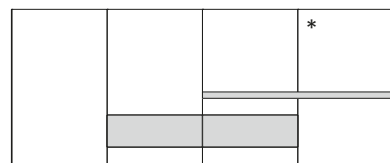

900
35 1/2"
900
35 1/2"
900
35 1/2"
960
37 3/4"

Per composizioni con boiserie laterali attrezzate con contenitori o mensole utilizzare pannelli 960-1260*, in modo tale che l'elemento non termini a filo.

For compositions with lateral wall panelling equipped with storage units or shelves, use w 37 3/4"- 49 1/2"* panels, so that the element does not end flush.

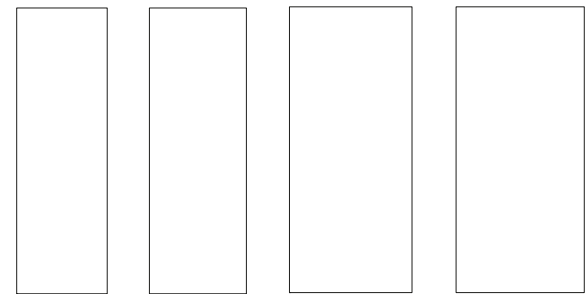

896
35 1/4"
956
37 3/4"
1196
47"
1256
49 1/2"

Carta da parati.
Wallpaper.



Profili laterali e centrali 4 mm.
Per boiserie h minore di 1900 sono previsti profili superiori.
Lateral and central profiles 5/32".
For wall panelling lower than 74 3/4" upper closing profiles are foreseen.

2700
106 1/4"

Mensoloni sospesi sp 60 p 500 Suspended thick shelves th 2 1/4" p 19 3/4"

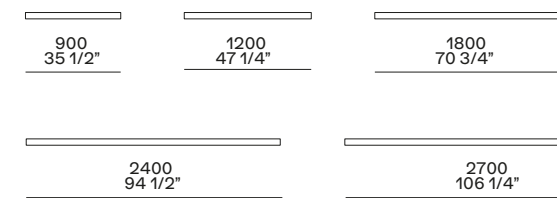

Canalina elettrificata opzionale, nella lunghezza del mensolone, sp 20 p 120.
Optional electrified channel in the same width of the thick shelf, th 3/4" d 4 3/4".

Mensole sp 8 p 280 con luce led opzionale Shelves th 5/16" d 11" with optional led light

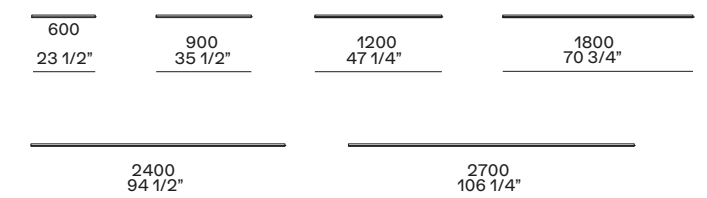

Pensili p 320 con luce led opzionale Hanging storage units d 12 1/2" with optional led light

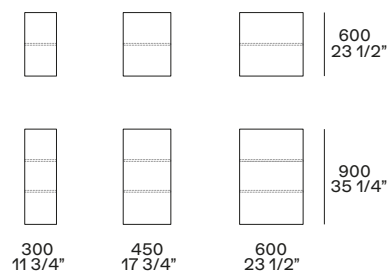

Con anta battente.
With leaf door.

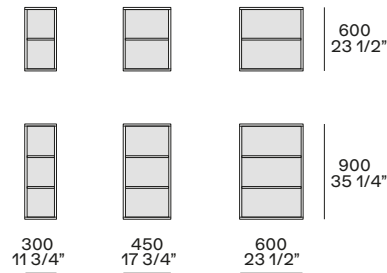

Con anta battente vetro.
With glass leaf door.

Bacheche sp 8 p 320 Open display cases th 5/16" p 12 1/2"

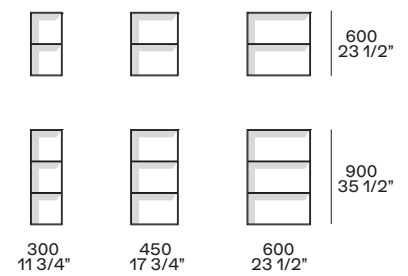

Contenitori bassi p 500
Low storage units d 19 3/4"

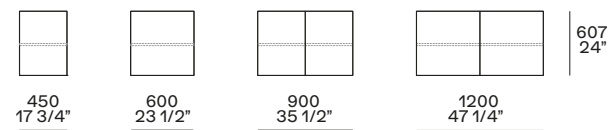

Con anta battente, a terra.
With leaf door, floorstanding.

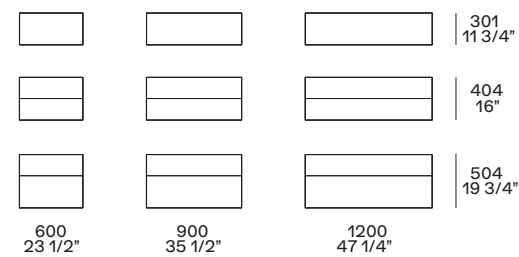

Con anta a ribalta o cassetti, sospesi o a terra. Nei contenitori a due vani l'anta a ribalta è prevista solo per il vano superiore.
With suspended or floorstanding lap door or drawers. For storage units with two compartments the flap door is available only for the upper compartment.

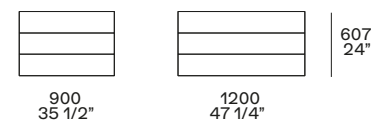

Con cassetti, sospesi o a terra.
With suspended or floorstanding drawers.

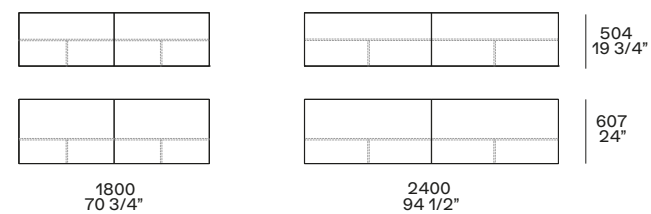

Con anta complanare, sospesi.
With coplanar door, suspended.

Per tutti i contenitori bassi aggiungere 8 mm per ogni fianco di copertura a inizio e fine composizione.
For all low storage units add 5/16" for each additional finishing side at the beginning and at the end of the composition.

Contenitori alti p 500 con luce led opzionale
Tall storage units d 19 3/4" with optional led light

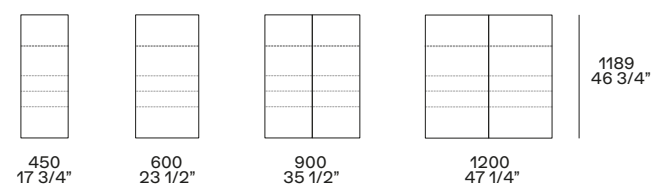

Ripiano vetro e cassetti.
Glass shelf and drawers.

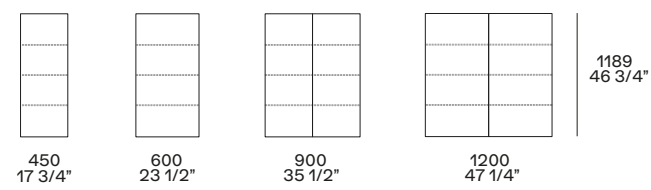

Ripiani vetro o legno
Glass or wooden shelves.

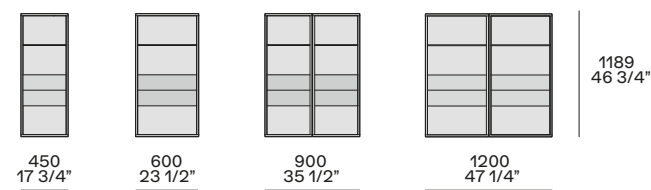

Ripiano vetro e cassetti.
Glass shelf and drawers.

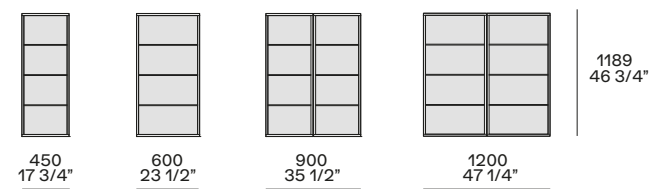

Ripiani vetro o legno.
Glass or wooden shelves.

Contenitori alti con anta battente legno o vetro, sospesi o a terra, fa eccezione l'1200 solo a terra.
Tall storage units with leaf door in wood or glass, suspended or floorstanding, except w 1200 available only floorstanding.

Vani a giorno sospesi o a terra p 500
Suspended or floorstanding open storage units d 19 3/4"

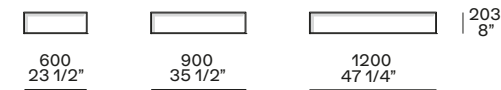

Da inserire sopra ai contenitori bassi h 301-404.
To be mounted on low storage units h 11 3/4"-16".

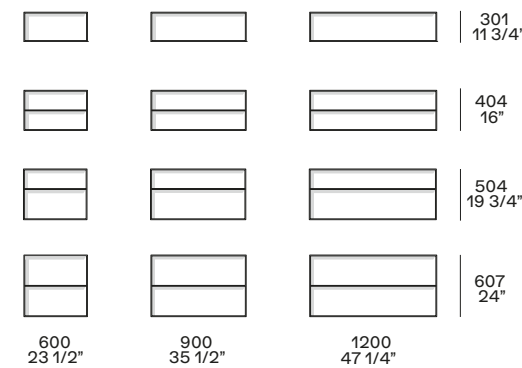

Da affiancare ai contenitori.
To be put next to storage units.

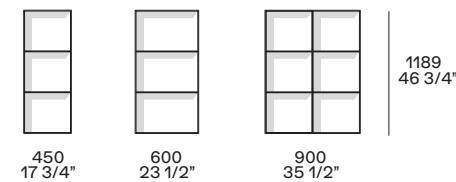
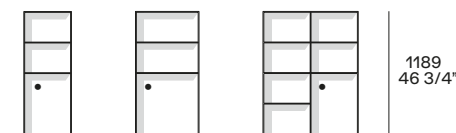
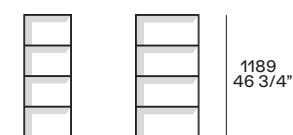

Da affiancare ai contenitori o al portale TV, luce led opzionale prevista solo per vani h 470".
To put next to storage units or TV portal, optional led light only for h 470" compartments.

Portale TV con luce led opzionale
TV-portal with optional led light

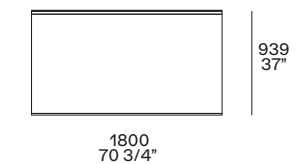

Da affiancare ai contenitori alti o vani a giorno h 1189.
Con cassetti o ribalta h 301.

To be put next to tall storage units or open storage units h 16 3/4".
With drawers or flap door h 11 3/4".

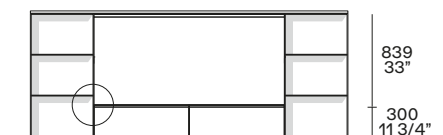
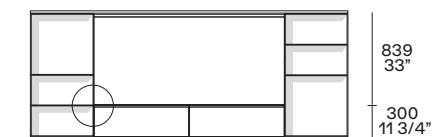

Esempi di composizioni con vani a giorno, portale TV h 839 e contenitori h 301.
I vani a giorno si allineano o meno al portale TV a seconda della versione scelta.

Examples of compositions with open storage units, TV portal h 33" and storage units h 11 3/4".
The open storage units can be aligned with the TV unit or not according to the chosen version.

NB
Non è possibile sovrapporre tra loro elementi bassi (sia contenitori che vani a giorno). L'unico elemento sovrapponibile è il vano giorno h 203, per creare pieni e vuoti.
Per composizioni in cui si affiancano elementi alti ad elementi bassi, aggiungere 8 mm per ogni fianco h 1189 inserito a lato del contenitore più alto per ogni accostamento alto-basso presente. In questo caso non sarà possibile inserire la boiserie. Per qualsiasi composizione la lunghezza top massima prevista è 2700 mm.

It is not possible to superimpose low elements (both storage units and open storage units). The only superimposable element is the open storage unit h 8" to create a design of closed and open storage units.
For compositions with tall and low elements one next to the other add 5/16" for each side h 46 3/4" next to the tallest storage unit and for every combination of tall-low units. In such case the wall panelling cannot be used.
For any composition the maximum length available of the top is 106 1/4".

CODE SIDEBOARD

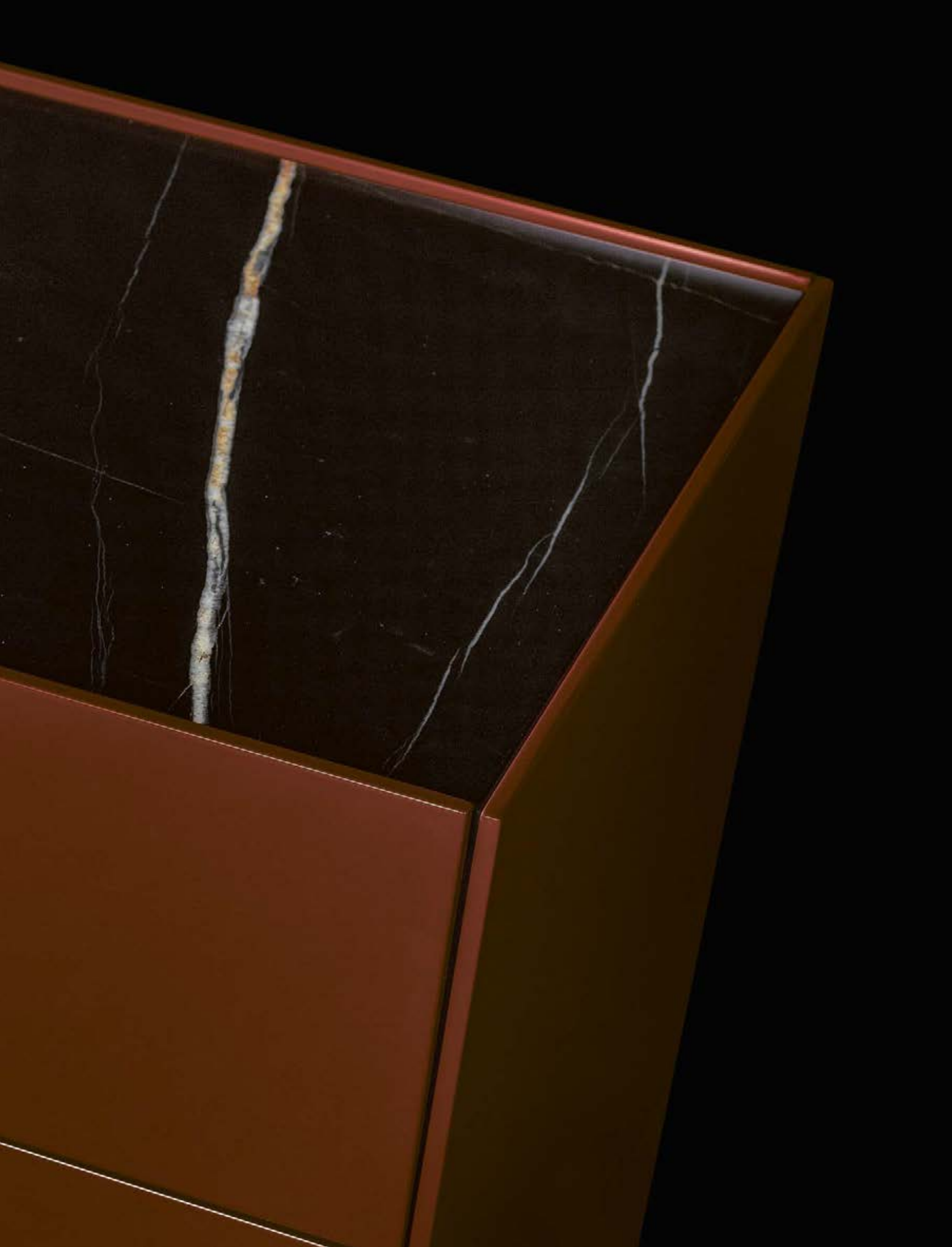

La collezione di madie Code completa l'omonimo sistema con una serie di contenitori disponibili in diverse configurazioni – con vani a giorno, cassetti e ante battenti o a ribalta. La versatilità del sistema si ritrova nella varietà di finiture, che danno a ogni madia uno stile diverso – più classico o più contemporaneo.

The Code sideboard collection completes the homonymous system with a series of containers available in different configurations – with open compartments, drawers, and hinged or folding doors. The versatility of the system can also be found in the variety of finishes, which give each sideboard a different style – more classic or more contemporary.

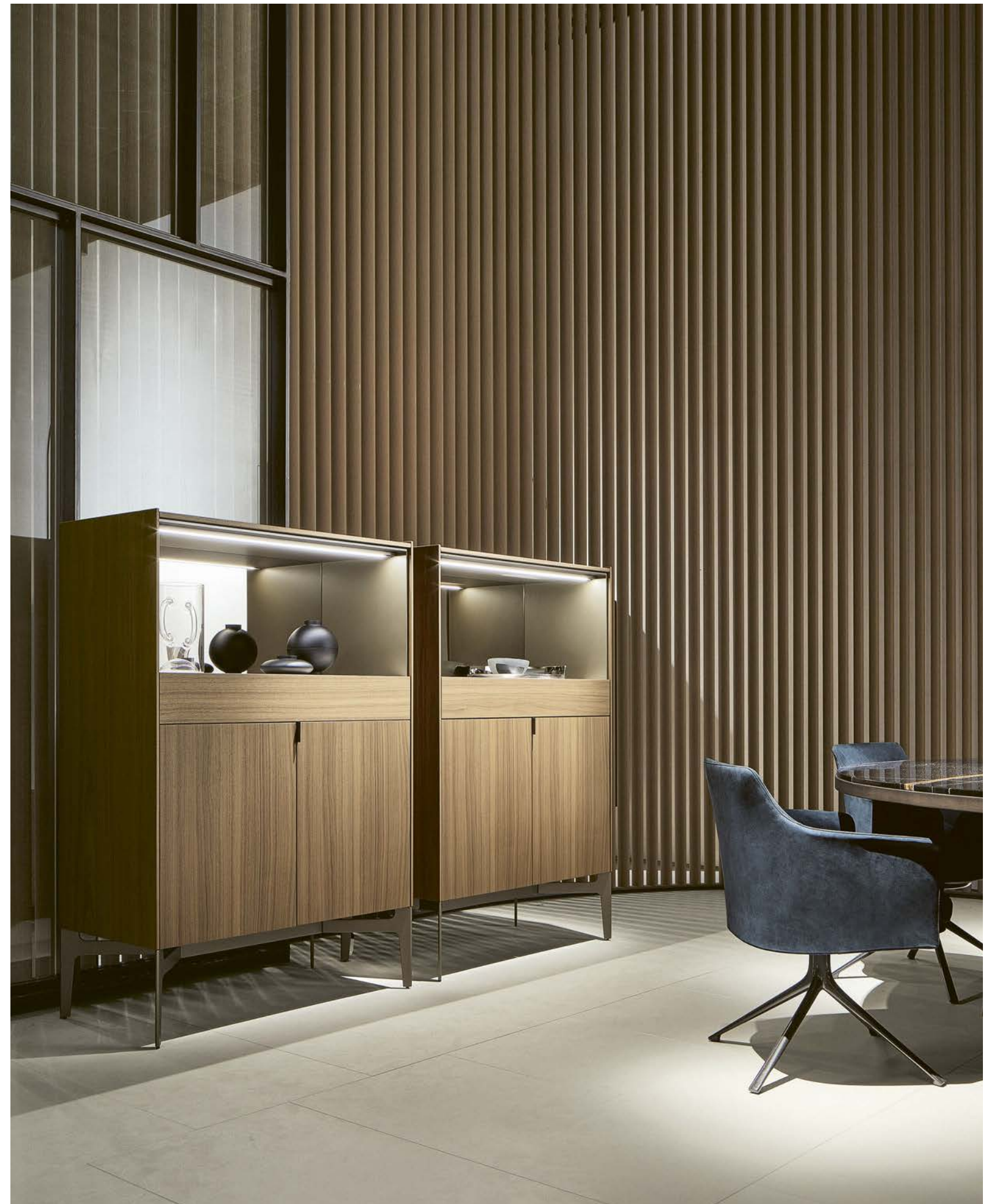

Qui e nella pagina precedente: madia Code in noce gold, vano a giorno con struttura in laccato opaco 77 champagne, schienale in specchio bronzo, top interno in marmo zecevo levigato e luce led integrata. Contenitore con ante battenti e cassetto superiore, struttura interna in laccato opaco 77 champagne. Ripiani interni in vetro trasparente 1000 e fondo cassetto in tecnopelle 06 nocciola. Basamento champagne opaco.

Here and on the previous page: Code sideboard in walnut gold, open compartment with structure in mat lacquered 77 champagne, bronze mirror back panel, internal top in zecevo mat marble and integrated led light. Storage unit with hinged doors and upper drawer, internal structure in mat lacquered 77 champagne. Internal shelves in transparent glass 1000 and drawer bottom in techno leather 06 nocciola. Base in mat champagne.

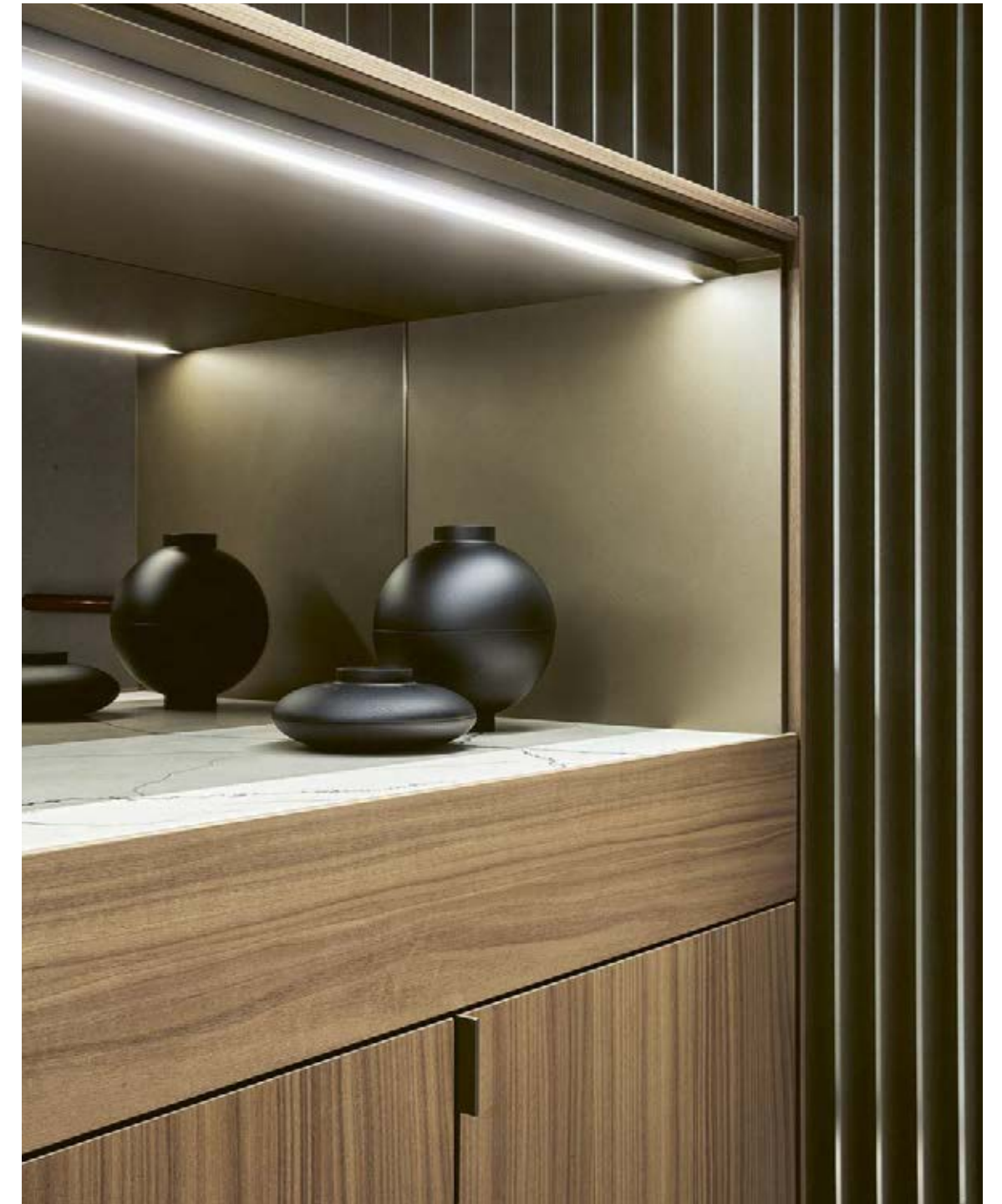



CODE SIDEBOARD

In questa pagina: madia Code in laccato semilucido 89 roccia con vano a giorno in laccato opaco 23 bronzo e top in laccato metallico 23 bronzo. Struttura interna cassetti in laccato opaco 02 ardesia e fondo cassetti in tecnopelle 06 nocciola. Basamento ardesia opaco.

On this page: Code sideboard in semi-glossy lacquered 89 roccia with open compartment in mat lacquered 23 bronzo and top in metal lacquer 23 bronzo. Drawers' internal structure in mat lacquered 02 ardesia and drawers' bottoms in techno leather 06 nocciola. Base in mat ardesia.



In questa pagina: madia Code in olmo nero e top in marmo zecevo levigato. Contenitore vetrina con luce led integrata, ante in vetro trasparente riflettente 5000, profili ardesia opaco, struttura interna in olmo nero, schienale in tessuto lino chiaro, frontale cassetti in laccato metallico 23 bronzo, interno cassetti in tecnopelle 06 nocciola, ripiano in vetro trasparente riflettente 5000. Vano a giorno con luce led integrata, struttura interna in laccato metallico 23 bronzo e schienali in olmo nero. Basamento ardesia opaco.

On this page: Code sideboard in black elm and top in zecevo mat marble. Display cabinet with integrated led light, doors in reflective transparent glass 5000, mat ardesia profiles, internal structure in black elm, backrest in fabric lino chiaro, drawer fronts in metal lacquer 23 bronzo, drawers' interior in techno leather 06 nocciola, shelf in reflective transparent glass 5000. Open compartment with integrated led light, internal structure in metal lacquer 23 bronzo and black elm back panels. Base in mat ardesia.



CODE SIDEBOARDS

Design R&D Poliform

Dati tecnici

Serie di madie disponibili in sette larghezze e quattro altezze, con diverse configurazioni. Disponibili con ante battenti o a ribalta in vetro o legno, cassetti e vani a giorno. Luce led integrata opzionale. Per le finiture disponibili vedere pagine dedicate.

Technical data

Series of sideboards available in seven widths and four heights, with different configurations. Available with hinged or flap doors in glass or wood, drawers, and open compartments. Optional integrated led light. For the available finishes see the dedicated pages.



Profondità 500 Depth 19 3/4"

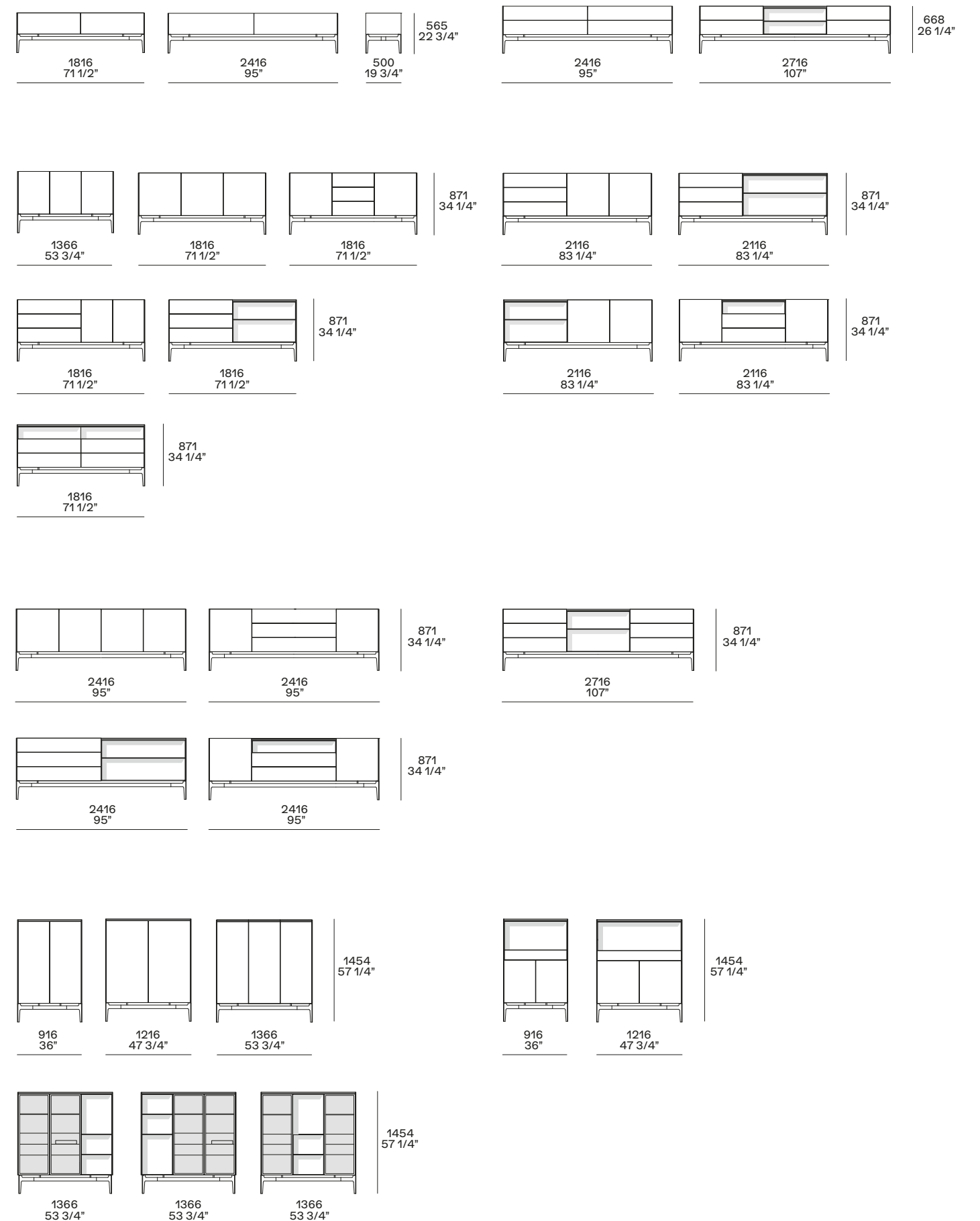

GENTLEMAN

Disegnata da Marcel Wanders, la collezione Gentleman è composta da divano fisso, pouf e tre poltrone di diverse dimensioni – compatta Gentleman Single, morbida e accogliente Gentleman Relax, fuori del comune Gentleman Reserved, con schienale alto. Una collezione di sedute dal comfort ineguagliabile, da usare singolarmente o tutte insieme.

Designed by Marcel Wanders, the Gentleman collection consists of a fixed sofa, ottoman, and three armchairs of different sizes – compact Gentleman Single, soft and cosy Gentleman Relax, outside-the-box Gentleman Reserved, with a tall backrest. A collection of seats with unparalleled comfort, to be used individually or all together.

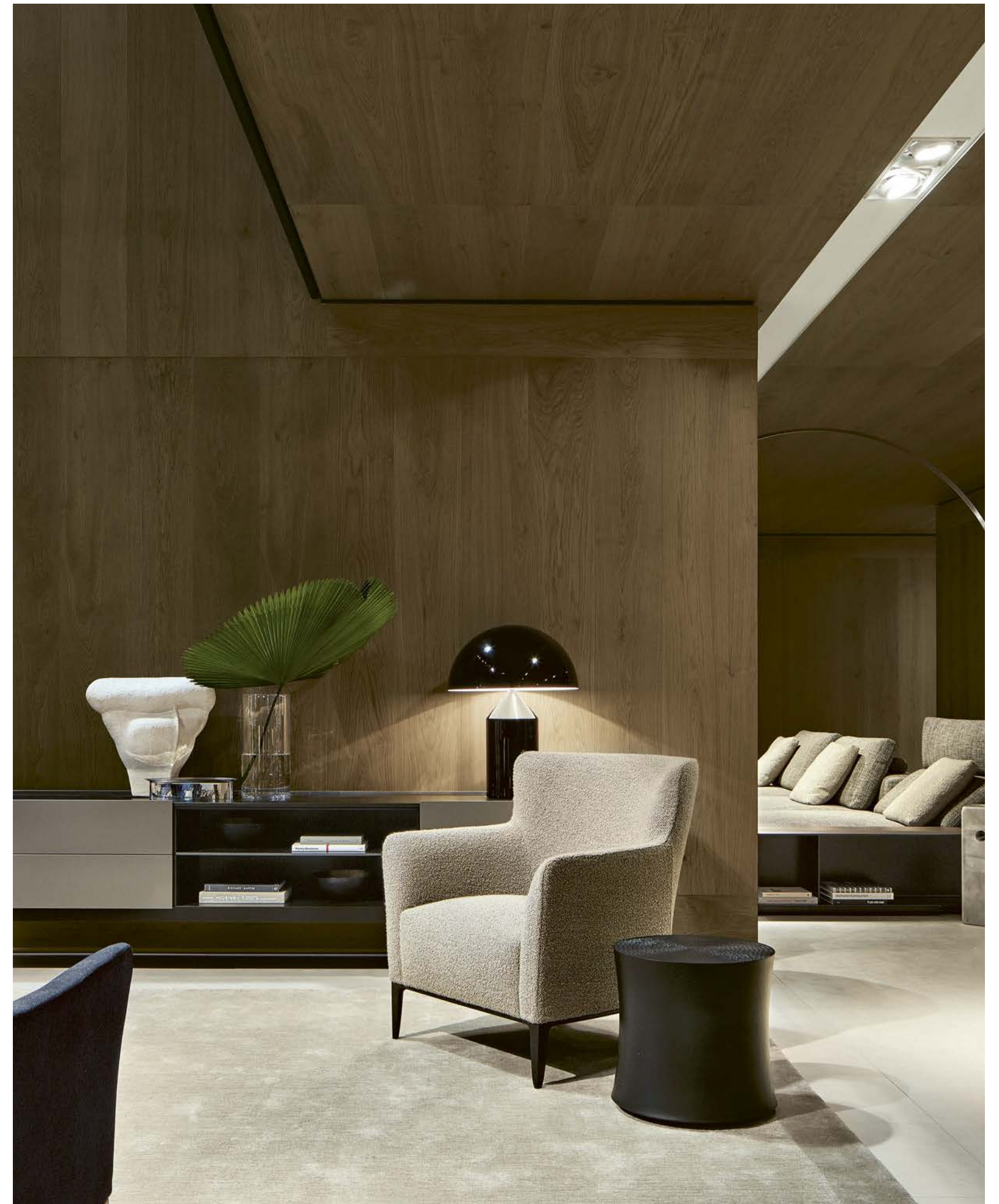



Qui e nella pagina successiva: poltrona Gentleman Reserved, rivestimento non sfoderabile, esterno in pelle Nabuk 09 ruggine e interno in Micene 03 sabbia, cuscini poggiatesta in pelle Nabuk 09 ruggine, basamento brown nickel lucido. Pouf Gentleman, rivestimento non sfoderabile in pelle Nabuk 09 ruggine e basamento brown nickel lucido. Nelle pagine precedenti: divano Gentleman's Friends, rivestimento sfoderabile in tessuto Tebe 08 notte, cuscini in tessuto Lero 01 ecrù e basamento brown nickel lucido. Poltrona Gentleman Relax e pouf Gentleman, rivestimento sfoderabile in tessuto Siro 02 lino e basamento brown nickel lucido.

Here and on the next page: Gentleman Reserved armchair, non-removable cover, exterior in Nabuk leather 09 ruggine and interior in Micene 03 sabbia, lower back cushions in Nabuk leather 09 ruggine, glossy brown nickel base. Gentleman footstool, non-removable cover in Nabuk leather 09 ruggine and base in glossy brown nickel. In the previous pages: Gentleman's Friends sofa, removable cover in Tebe fabric 08 notte, cushions in Lero fabric 01 ecrù and base in glossy brown nickel. Gentleman Relax armchair and Gentleman footstool, removable cover in Siro fabric 02 lino and glossy brown nickel base.





Qui e nella pagina successiva: poltrona Gentleman Single, rivestimento non sfoderabile in pelle Silk 12 senape, basamento brown nickel lucido. Divano Gentleman's Friends, rivestimento sfoderabile in tessuto Arcadia 05 bronzo, cuscini in velluto Persia 1404 carbone con bordura gros-grain acciaio. Basamento brown nickel lucido.

Here and on the next page: Gentleman Single armchair, non-removable cover in Silk leather 12 senape, glossy brown nickel base. Gentleman's Friends sofa, removable cover in Arcadia fabric 05 bronzo, cushions in Persia velvet 1404 carbone with border in grosgrain acciaio. Glossy brown nickel base.





GENTLEMAN SINGLE

Design Marcel Wanders

Dati tecnici

Scocca e seduta in poliuretano espanso a quote differenziate. Prerivestimento in ovatta di poliestere. Piedi e profili in alluminio, finitura champagne opaco, brown nickel opaco o lucido. Rivestimento in tessuto sfoderabile o in pelle non sfoderabile.

Technical data

Body and seat in multi-density polyurethane foam. Pre-cover in polyester wadding. Feet and profiles in aluminium, finish mat champagne, mat or glossy brown nickel. Removable fabric cover or non-removable leather cover.

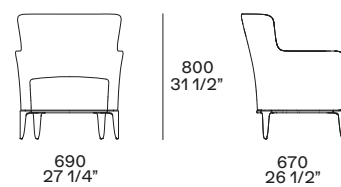

GENTLEMAN RELAX

Design Marcel Wanders

Dati tecnici

Scocca e seduta in poliuretano espanso a quote differenziate. Prerivestimento in ovatta di poliestere. Piedi e profili in alluminio, finitura champagne opaco, brown nickel opaco o lucido. Rivestimento in tessuto sfoderabile o in pelle non sfoderabile.

Technical data

Body and seat in multi-density polyurethane foam. Pre-cover in polyester wadding. Feet and profiles in aluminium, finish mat champagne, mat or glossy brown nickel. Removable fabric cover or non-removable leather cover.

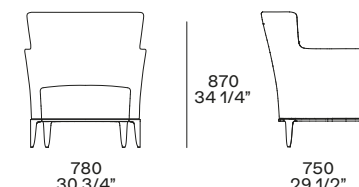

GENTLEMAN POUF

Design Marcel Wanders

Dati tecnici

Seduta in poliuretano espanso a quote differenziate. Prerivestimento in ovatta di poliestere. Piedi e profili in alluminio, finitura champagne opaco, brown nickel opaco o lucido. Rivestimento in tessuto sfoderabile o in pelle non sfoderabile.

Technical data

Seat in multi-density polyurethane foam. Pre-cover in polyester wadding. Feet and profiles in aluminium, finish mat champagne, mat or glossy brown nickel. Removable fabric cover or non-removable leather cover.

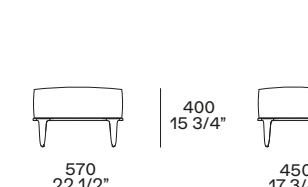

GENTLEMAN RESERVED

Design Marcel Wanders

Dati tecnici

Scocca e seduta in poliuretano espanso a quote differenziate. Prerivestimento in ovatta di poliestere. Piedi e profili in alluminio, finitura champagne opaco, brown nickel opaco o lucido. Rivestimento in tessuto sfoderabile o in pelle non sfoderabile. Possibilità di rivestimento diverso tra interno ed esterno della scocca. Cuscino salvareni opzionale con rivestimento sfoderabile in tessuto o sfoderabile in pelle con cucitura doppia.

Technical data

Body and seat in multi-density polyurethane foam. Pre-cover in polyester wadding. Feet and profiles in aluminium, finish mat champagne, mat or glossy brown nickel. Removable fabric cover or non-removable leather cover. The inner and the outer cover of the body can be in two different material. Optional lower back cushion with removable cover in fabric or removable cover in leather with double stitching.

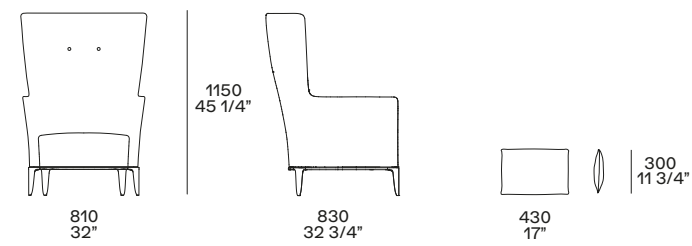

cuscinio salvareni
kidneyrest cushion



GENTLEMAN'S FRIENDS

Design Marcel Wanders

Dati tecnici

Scocca e seduta in poliuretano espanso a quote differenziate. Prerivestimento in ovatta di poliestere. Piedi e profili in alluminio, finitura champagne opaco, brown nickel opaco o lucido. Rivestimento in tessuto sfoderabile o in pelle non sfoderabile. Cuscini con rivestimento sfoderabile in tessuto con bordura gros-grain o sfoderabile in pelle con cucitura doppia.

Technical data

Body and seat in multi-density polyurethane foam. Pre-cover in polyester wadding. Feet and profiles in aluminium, finish mat champagne, mat or glossy brown nickel. Removable fabric cover or non-removable leather cover. Cushions with removable cover in fabric with grosgrain border or removable cover in leather with double stitching.

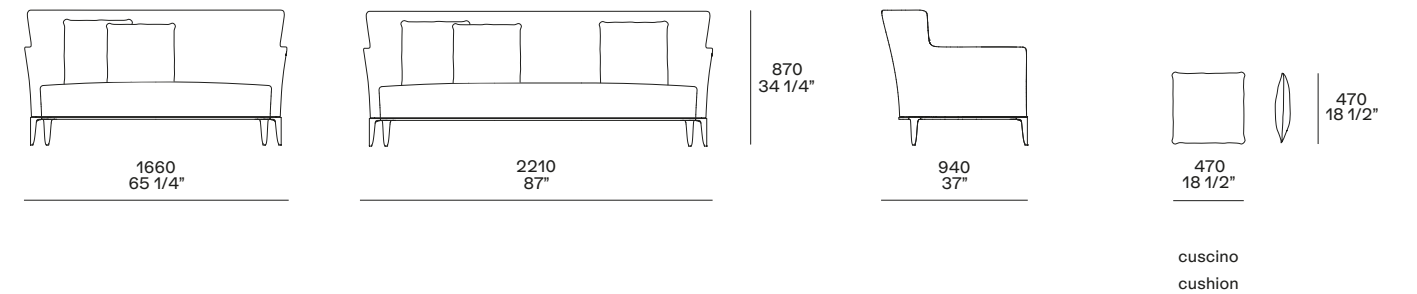

cuscinio
cushion



NARA

Tavolino o sgabello, pouf o comodino: Nara è un complemento trasversale, ideale nei più diversi contesti. Disegnato da Jean-Marie Massaud, è realizzato in legno massello e caratterizzato dalla base lavorata.

Coffee table or stool, footstool or bedside table: Nara is a universal complement, ideal in the most diverse contexts. Designed by Jean-Marie Massaud, it is made of solid wood and characterized by an elaborate base.





NARA

Design Jean-Marie Massaud

Dati tecnici

Struttura e piano in legno massello
noce gold o tinto olmo nero.

Technical data

Structure and top in solid wood walnut
gold or stained black elm.

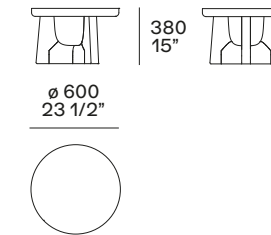
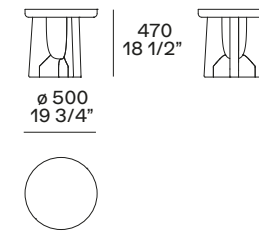

Sopra e nella pagina precedente: tavolini Nara in legno massello noce gold.

Above and on the previous page: Nara coffee tables in solid wood walnut gold.



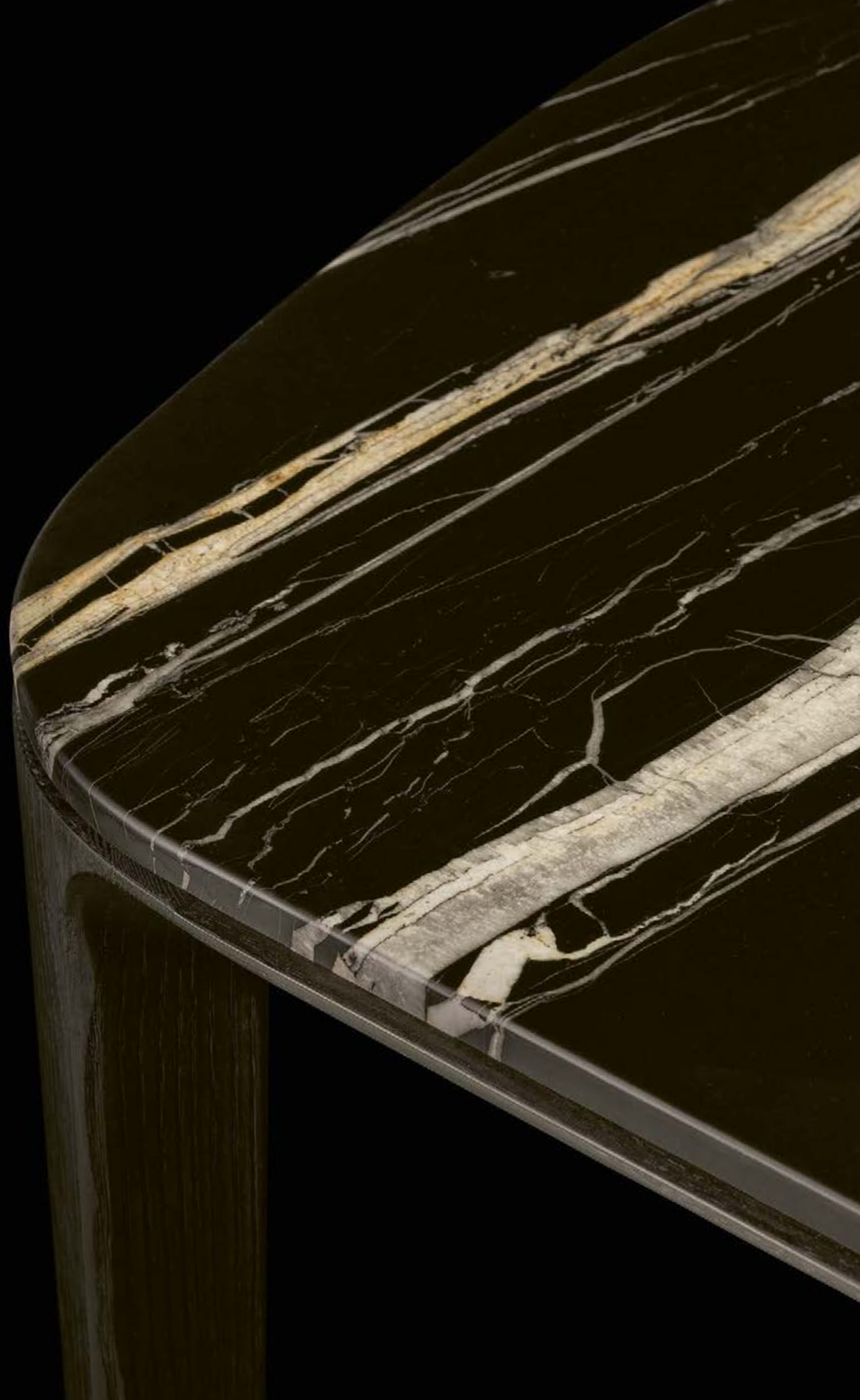

HENRY

Evoluzione dell'omonimo tavolino, Henry è un tavolo da pranzo allungabile dalle dimensioni importanti. Pensato per la convivialità, è disponibile nelle versioni rettangolare e quadrata, sempre con angoli stondati. Eleganti le finiture: la struttura è in legno massello, caratterizzata da una raffinata lavorazione di ebanisteria. Il piano è in legno, marmo o vetro.

An evolution of the homonymous coffee table, Henry is a large, extendable dining table. Designed for conviviality, it is available in the rectangular and square versions, always with rounded corners. The finishes are elegant: the structure is in solid wood, characterized by a refined cabinetwork. The top is in wood, marble, or glass.

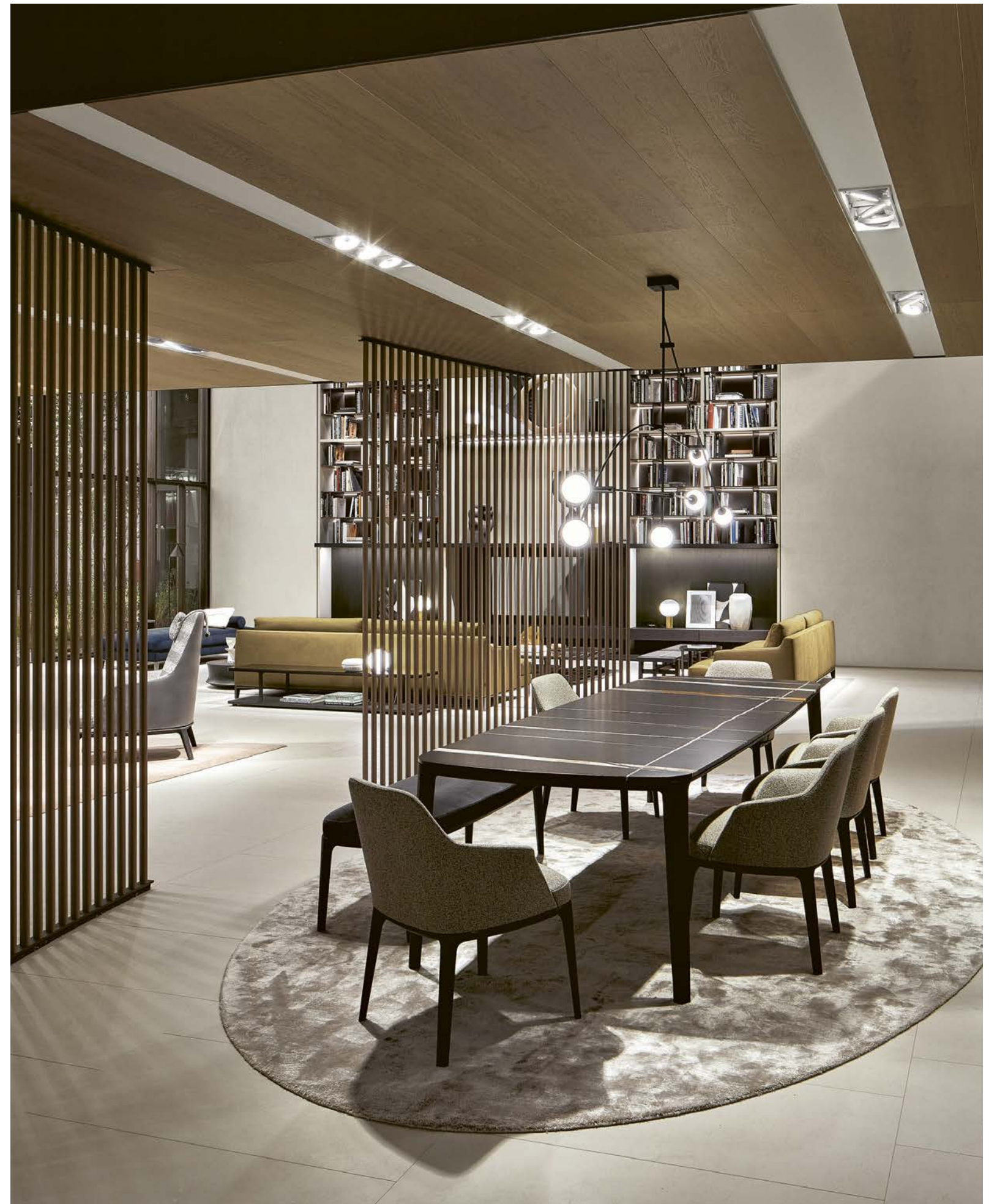



Qui e nelle pagine precedenti: tavolo Henry con struttura in olmo nero e piano in marmo sahara noir levigato finitura poliester.

Here and on the previous pages: Henry table with structure in black elm and top in sahara noir mat marble with polyester finish.



HENRY

Design Emmanuel Gallina

Dati tecnici

Tavolo fisso o allungabile. Struttura in massello, finitura in olmo nero o noce gold. Piano in olmo nero, noce gold, cinque marmi levigati e sei lucidi, vetro lucido nei colori 2273 ghiaccio, 1264 arena, 1204 grafite, 2259 bordeaux. Il piano in olmo nero e noce gold è caratterizzato dall'accostamento di lastre con venatura a spina di pesce. La versione allungabile prevede solo il piano in olmo nero o noce gold.

Technical data

Fixed or extendable table. Solid wood structure, black elm or walnut gold finish. Top in black elm, walnut gold, five mat marbles and six glossy marbles, glossy glass in the colours 2273 ghiaccio, 1264 arena, 1204 grafite, 2259 bordeaux. The top in black elm and walnut gold is characterized by the combination of veneers with herringbone grain. The extendable version has only the top in black elm or walnut gold.



Piano in legno Wooden top

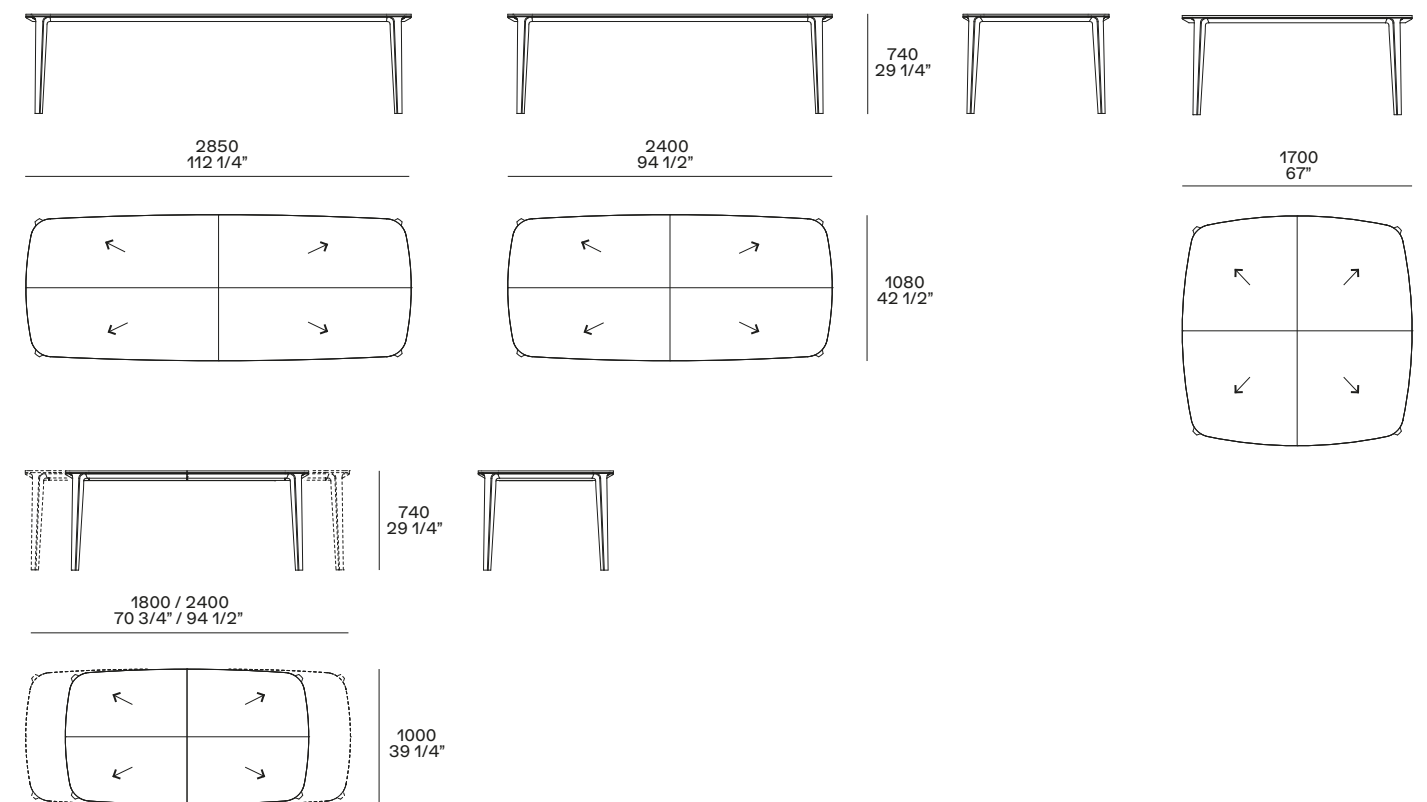

Le frecce indicano l'orientamento delle venature del legno.
The arrows show the direction of the wooden grain.

Piano in marmo e vetro Marble and glass top

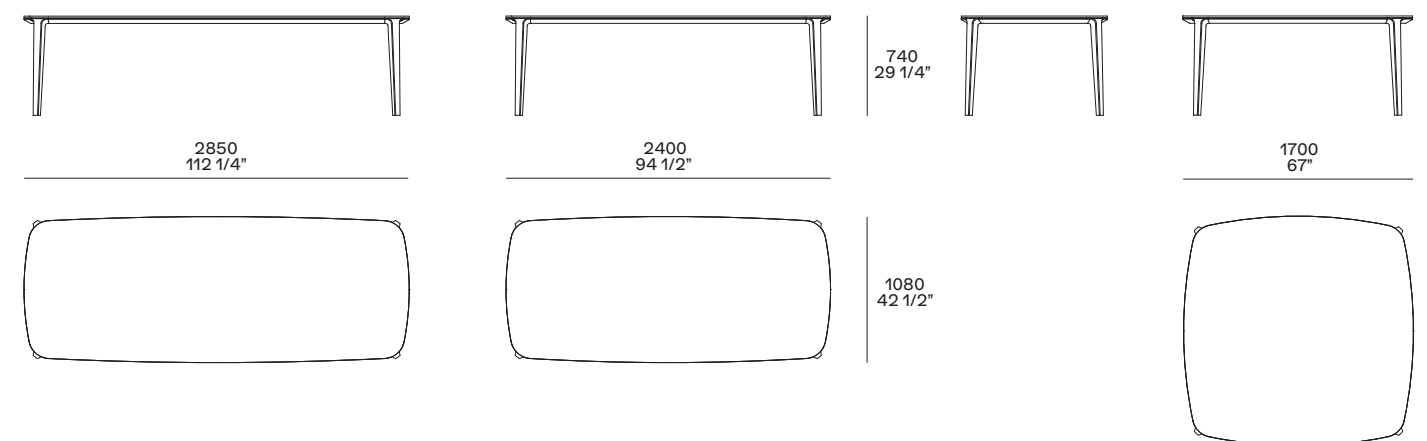

MONDRIAN

Jean-Marie Massaud reinterpreta il design leggero ed elegante della collezione Mondrian nel tavolo da pranzo. Due le varianti del piano, ovale o rotondo, in legno, vetro o marmo. La particolare struttura in metallo è disponibile anche nella nuova finitura champagne.

Jean-Marie Massaud reinterprets the light and elegant design of the Mondrian collection in the dining table. Two variants of the top, oval or round, in wood, glass or marble. The particular metal structure is also available in the new champagne finish.

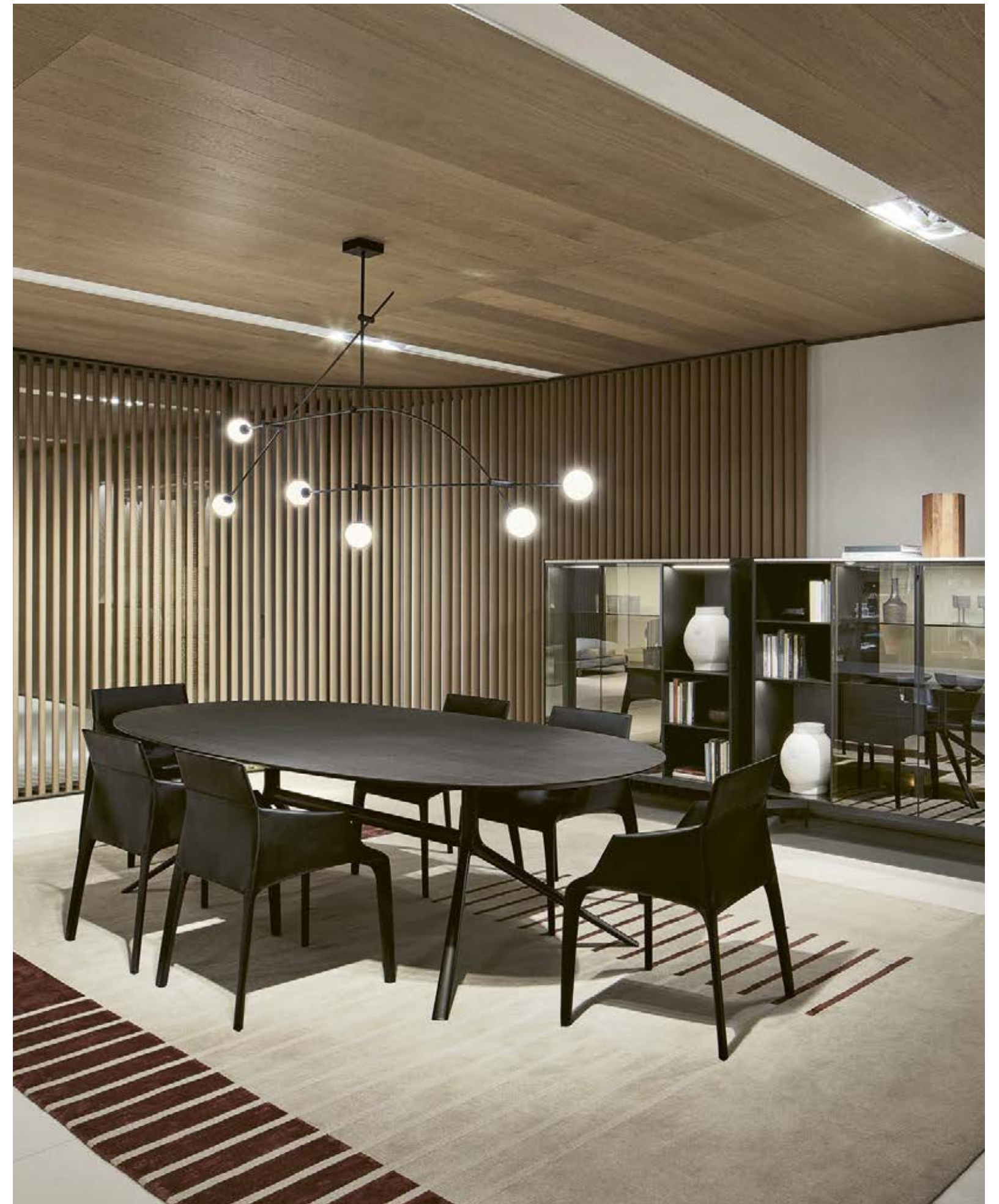





MONDRIAN

Design Jean-Marie Massaud

Dati tecnici

Struttura in fusione di alluminio, finitura brown nickel opaco o champagne opaco.
Piano in olmo nero, noce gold, vetro fumé 3050, cinque marmi levigati e sei lucidi.

Technical data

Structure in aluminium casting, finish mat brown nickel or mat champagne.

Top in black elm, walnut gold, 3050 fumé glass, five mat marbles and six glossy marbles.

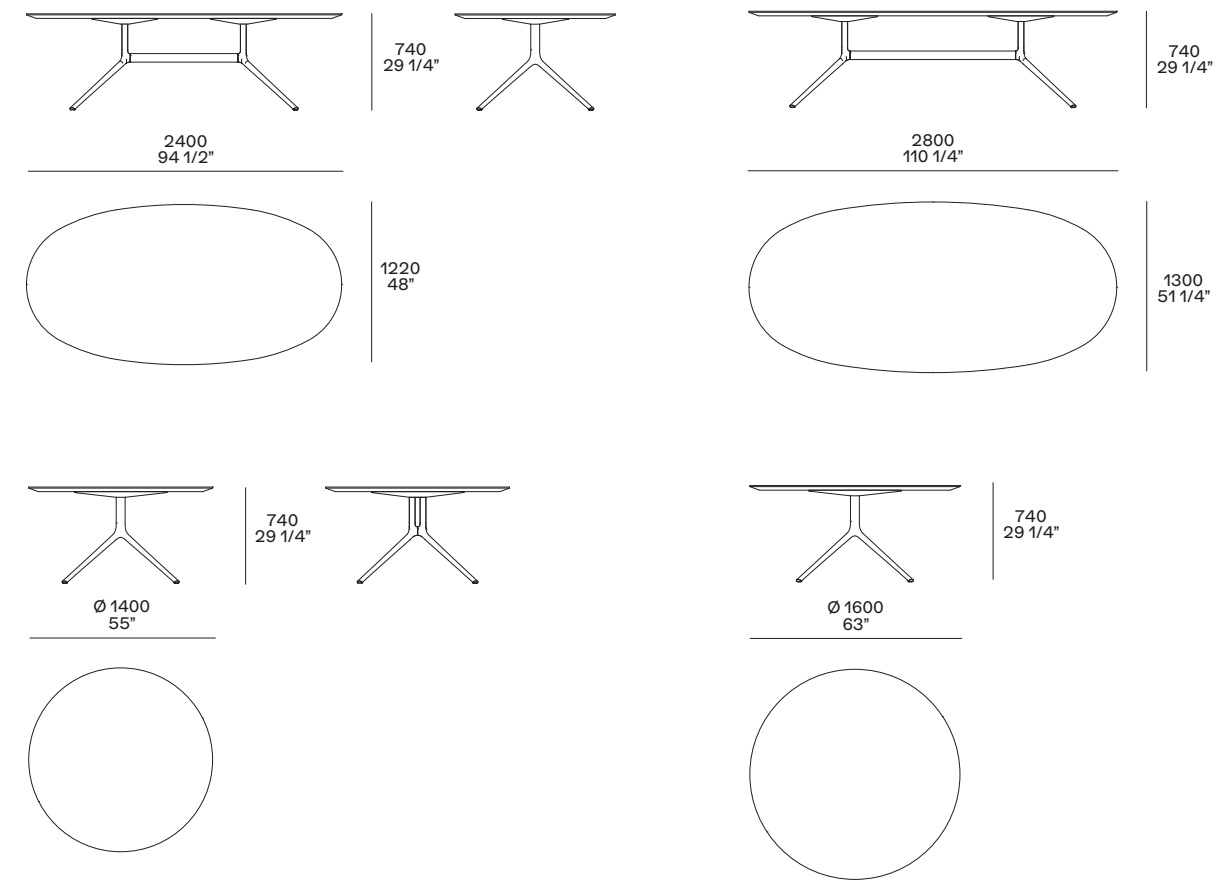

Sopra e nelle pagine precedenti: tavolo Mondrian con struttura brown nickel opaco e piano in olmo nero.

Above and on the previous pages: Mondrian table with mat brown nickel structure and black elm top.



HOME HOTEL

Nuova finitura per il tavolo della collezione Home Hotel disegnato da Jean-Marie Massaud. Il piano in marmo è integrato nello spessore del legno, una lavorazione di grande maestria che unisce estetica e saper fare.

New finish for the table of the Home Hotel collection designed by Jean-Marie Massaud. The marble top is integrated into the thickness of the wood, a work of great mastery that combines style and know-how.

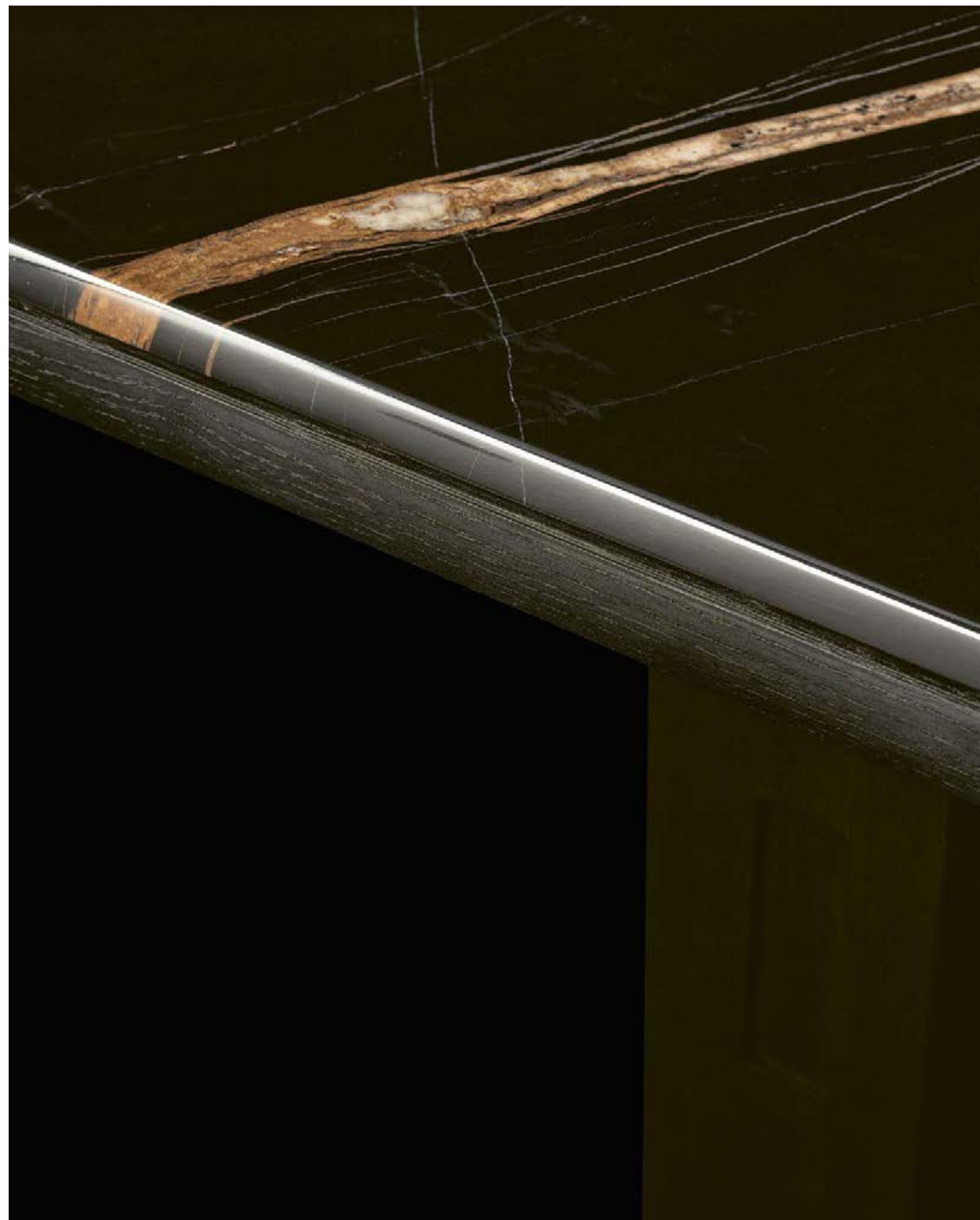

HOME HOTEL
Design Jean-Marie Massaud

Dati tecnici

Struttura in massello finitura olmo nero o massello noce gold. Piano in olmo nero, cinque marmi levigati e sei lucidi. Versione in noce gold disponibile solo con piano in marmo.
I tavoli \varnothing 1800 e 2000 mm hanno un piano girevole integrato in olmo nero, noce gold, cinque marmi levigati e sei lucidi.
Per i tavoli \varnothing 1800 e 2000 con piani in marmo, il piano girevole è disponibile solo in olmo nero o noce gold.

Technical data

Structure in solid wood finish black elm or solid walnut gold. Top in black elm, five mat marbles and six glossy marbles. Version in walnut gold available only with top in marble.
The tables \varnothing 70 3/4" and 78 3/4" have an integrated swivel top in black elm, walnut gold, five mat and six glossy marble finishes.
For tables \varnothing 70 3/4" and 78 3/4" with marble top the swivel top is available only in black elm or walnut gold.

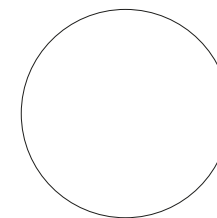
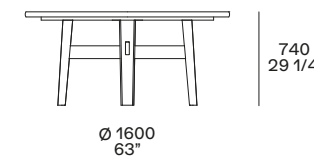
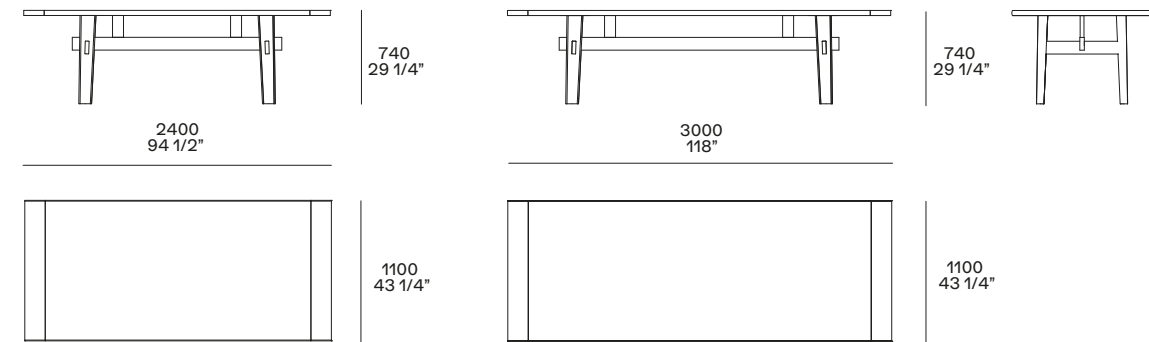

Con piano girevole integrato
With integrated swivel top

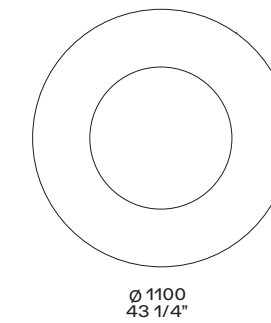
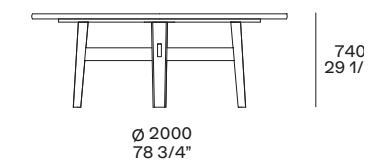
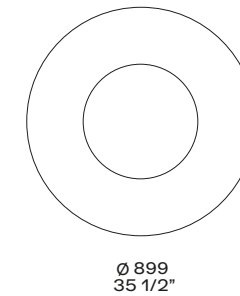
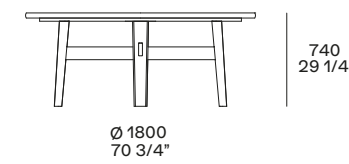

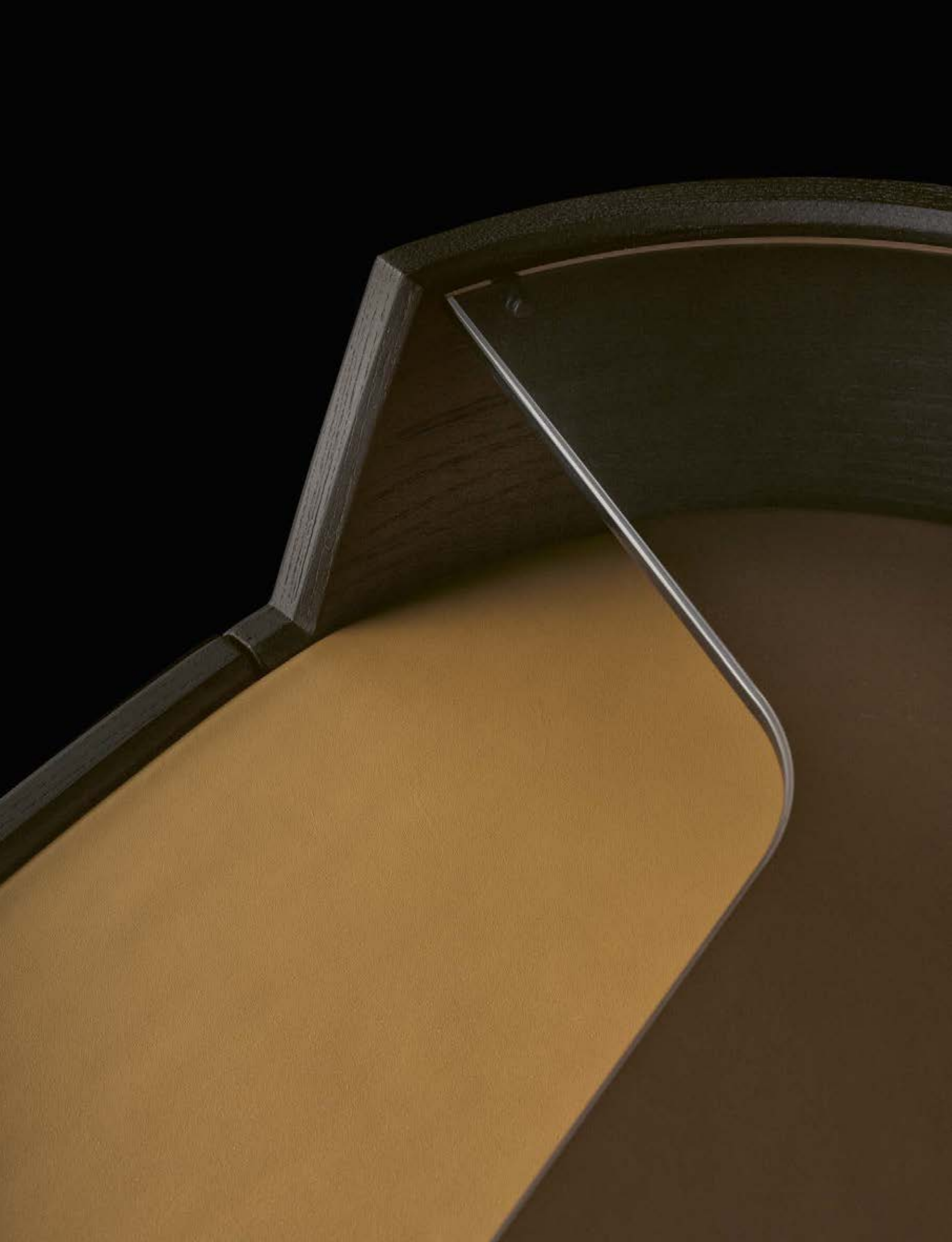

KELLY

Emmanuel Gallina ridisegna la cassettera e il comodino della collezione Kelly. La cassettera – con tre cassetti e piano in laccato, cuoio o marmo – è impreziosita dal piccolo piano portaoggetti in vetro. Il comodino dalle forme generose e arrotondate si appoggia a terra.

Emmanuel Gallina redesigns the dresser and the bedside table of the Kelly collection. The dresser – with three drawers and top in lacquered, hide, or marble – is embellished by the small glass shelf. The bedside table with generous and rounded shapes rests on the floor.

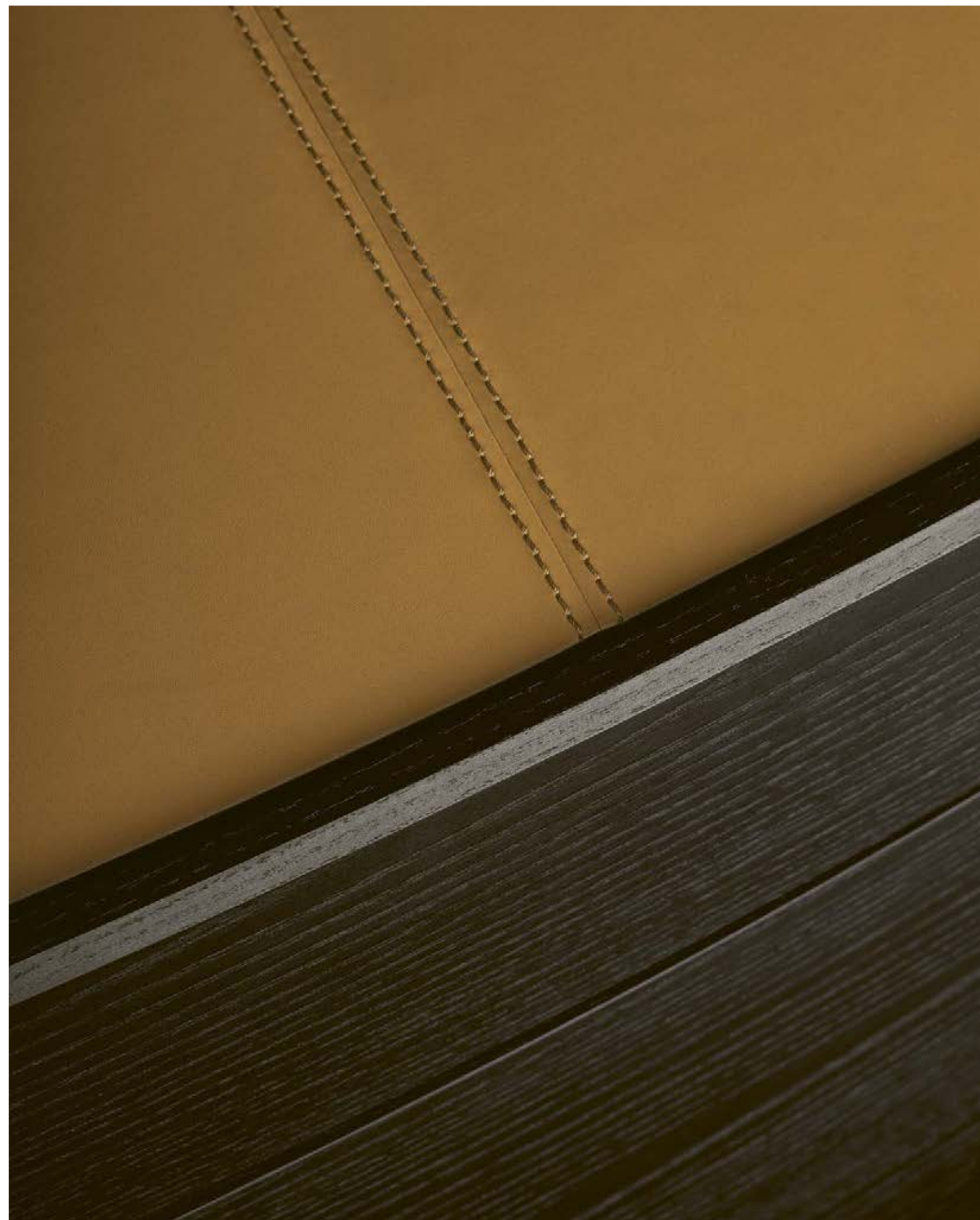

KELLY

Design Emmanuel Gallina

Dati tecnici

Struttura rovere spessart, olmo nero e noce gold. Top in laccato opaco colori, laccato lucido colori, cuoio, cinque marmi levigati e sei lucidi. Cassettiera con mensola superiore in vetro nella finitura fumé 3050 o bronzato 5051.

Technical data

Structure in spessart oak, black elm and walnut gold. Top in mat lacquered colours, glossy lacquered colours, hide, five mat marbles and six glossy marbles. Chest of drawers with upper shelf in glass 3050 fumé or 5051 bronzed.

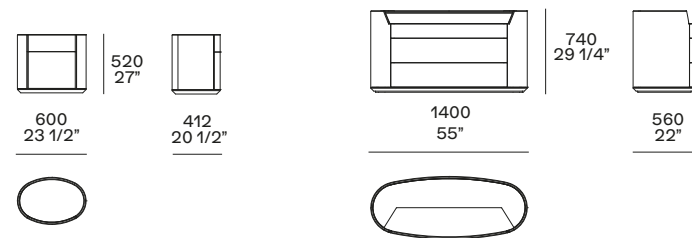

KELLY

Design Emmanuel Gallina

Dati tecnici

Struttura rovere spessart, olmo nero e noce gold. Top in laccato opaco colori, laccato lucido colori, cuoio, cinque marmi levigati e sei lucidi. Piedi in metallo finitura brown nickel opaco o lucido.

Technical data

Structure in spessart oak, black elm and walnut gold. Top in mat lacquered colours, glossy lacquered colours, hide, five mat marbles and six glossy marbles. Feet in mat or glossy brown nickel metal.

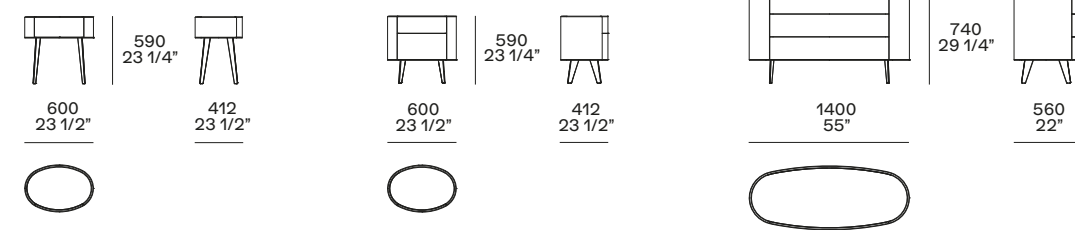

SENZAFINE

Il sistema di armadi Senzafine si arricchisce di nuove ante, finiture e accessori, all'insegna di un'eleganza discreta e di una grande libertà compositiva. Un armadio che ora si può davvero cucire su misura – ancora più prezioso con le nuove finiture metalliche ardesia e champagne.

The Senzafine wardrobes system is enriched by new doors, finishes, and accessories, in the name of discreet elegance and great compositional freedom. A wardrobe that can now be truly tailored – even more precious with the new ardesia and champagne metallic finishes.

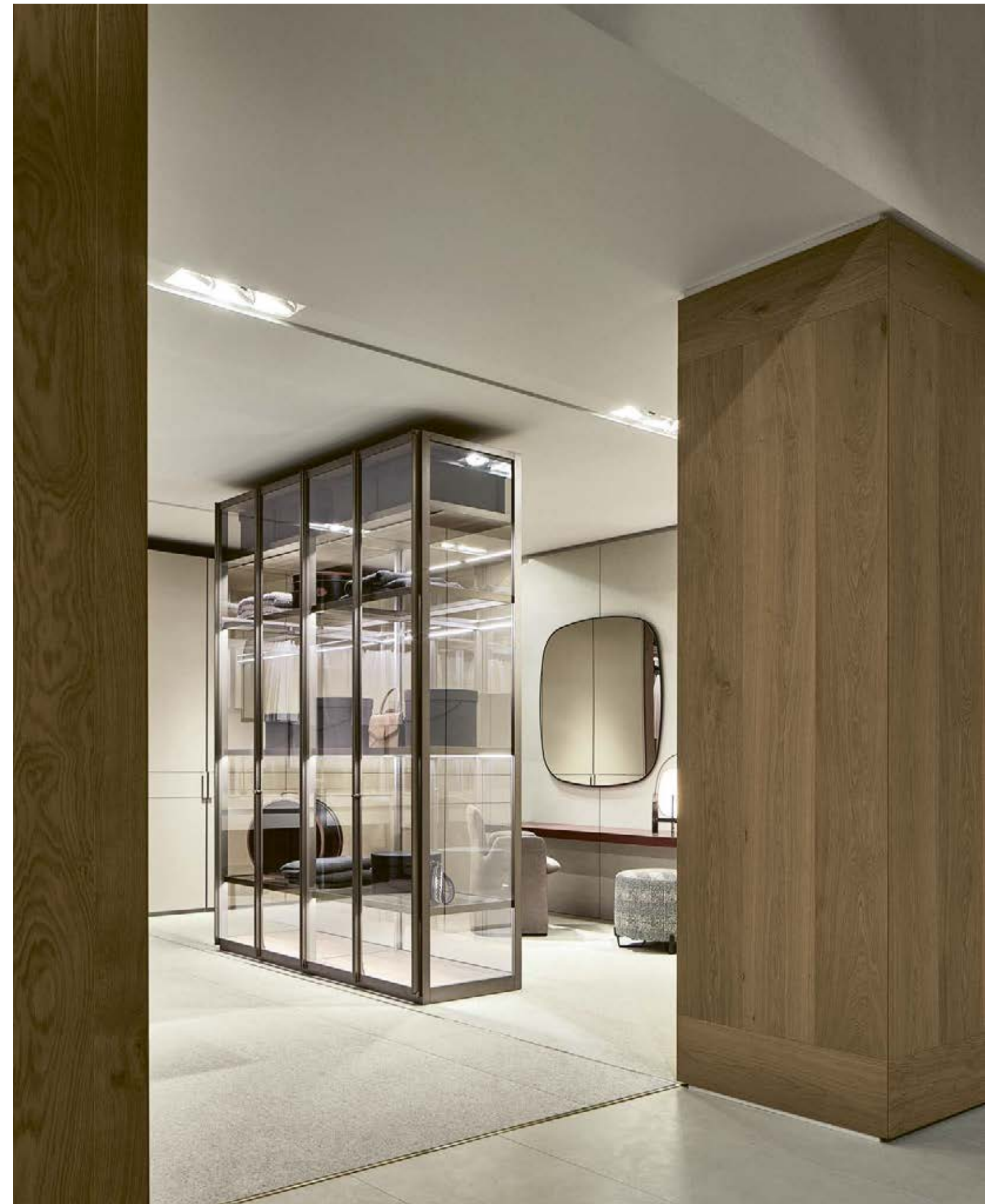





Nella pagina introduttiva e nella precedente: armadio Senzafine Ego apertura battente, ante in vetro trasparente riflettente 5000 e telaio champagne opaco. Fianchi laterali e schienali in vetro trasparente riflettente 5000. Top e basi in nobilitato olmo, bordo anteriore champagne opaco. Ripiani interni in vetro fumé 3050 e telaio champagne opaco. Qui, nella pagina precedente e nella successiva: cabina armadio Senzafine, struttura champagne opaco con schienali in metacrilato roller latte. Top, base e ripiani interni in nobilitato olmo con profili champagne opaco. Zoccolo opzionale champagne opaco. Cassettiera a vetrina sospesa con piano superiore in vetro fumé 3050, vassoio estraibile con frontale laccato opaco champagne, fondo cassetto in tecnopelle 05 latte. Cassetti inferiori con frontali in metacrilato roller latte, maniglia Track champagne opaco e fondo cassetto in tecnopelle 05 latte. Tubi appendiabiti in tecnopelle 05 latte.

On the introductory page and on the previous one: Senzafine Ego wardrobe with leaf doors, doors in reflective transparent glass 5000 and mat champagne frame. Side panels and back panels in reflective transparent glass 5000. Tops and bases in elm melamine, mat champagne front edge. Internal shelves in fumé glass 3050 and mat champagne frame. Here, on the previous and next page: Senzafine walk-in closet, mat champagne structure with latte methacrylate roller back panels. Top, base, and internal shelves in elm melamine with mat champagne profiles. Optional mat champagne support. Suspended display case dresser with upper top in fumé glass 3050, pull-out tray with champagne mat lacquered front, drawer bottom in techno leather 05 latte. Lower drawers with latte methacrylate roller fronts, mat champagne Track handle and drawer bottom in techno leather 05 latte. Hanging rails in techno leather 05 latte.







Qui e nella pagina successiva: armadi Senzafine Cover apertura battente e complanare, ante in tecnopelle 05 latte con profili champagne opaco, maniglie Cover in tecnopelle 05 latte con profili champagne opaco, maniglie Fitted champagne opaco. Fianchi laterali in tecnopelle 05 latte. Zoccolo opzionale champagne opaco.

Here and on the next page: Senzafine Cover wardrobes with leaf and coplanar opening, doors in techno leather 05 latte with mat champagne profiles, Cover handles in techno leather 05 latte with mat champagne profiles, mat champagne Fitted handles. Side panels in techno leather 05 latte. Optional mat champagne support.





Sotto: dettaglio dell'anta e maniglia Cover in tecnopelle 05 latte e profili champagne opaco. A sinistra: dettaglio del portacamicie con struttura in nobilitato olmo, ripiani interni in tecnopelle 05 latte e cassette rivestiti in tessuto in finitura ardesia. Schienale in nobilitato skin laccato opaco 05 latte e fianco in nobilitato olmo. Tubo appendiabiti champagne opaco.

Below: detail of the door and Cover handle in techno leather 05 latte and mat champagne profiles. On the left: detail of the skirt holder with structure in elm melamine, internal shelves in techno leather 05 latte and drawers covered in fabric in ardesia finish. Back panel in skin melamine mat lacquered 05 latte and side in elm melamine. Mat champagne hanging rails.



In questa pagina pagina: armadio Senzafine Cover apertura complanare, ante in tecnopelle 05 latte con profili champagne opaco e maniglie Fitted champagne opaco. Struttura e schienali in nobilitato canvas beige e fianchi laterali in tecnopelle 05 latte. Ripiani interni in nobilitato olmo con bordo anteriore champagne opaco. Cassettiere con struttura e frontale in nobilitato olmo, top e vassoi in tecnopelle 05 latte. Tubi appendiabiti champagne opaco.

On this page: Senzafine Cover wardrobe with coplanar opening, doors in techno leather 05 latte with mat champagne profiles and mat champagne Fitted handles. Structure and back panels in canvas beige melamine and side panels in techno leather 05 latte. Inner shelves in elm melamine with mat champagne front edge. Dressers with structure and front in elm melamine, top and trays in techno leather 05 latte. Mat champagne hanging rails.





Sotto: dettaglio dell'anta Cover in tecnopelle 05 latte con profili champagne opaco e maniglia Fitted champagne opaco. A sinistra: dettaglio del tubo appendiabiti champagne opaco, ripiano in nobilitato olmo con bordo anteriore champagne opaco e luce led integrata.

Below: detail of the Cover door in techno leather 05 latte with mat champagne profiles and mat champagne Fitted handle. On the left: detail of the mat champagne closet rod, top in elm melamine with mat champagne front edge and integrated led light.





Qui e nella pagina precedente: armadio Senzafine Cover apertura battente, ante Cover in tessuto lino chiaro con profili champagne opaco e maniglie Fitted champagne opaco. Struttura e schienali in nobilitato canvas beige e fianchi laterali in tessuto lino chiaro. Zoccolo opzionale champagne opaco. Ripiani interni in nobilitato olmo con bordo anteriore champagne opaco. Cassettiere con top in tecnopelle 05 latte, frontali in vetro riflettente fumé 5059, maniglie Track e bordo anteriore del top champagne opaco. Interno cassetti in nobilitato ardesia e fondo in tecnopelle 05 latte. Accessori svuota tasche in laccato opaco champagne con piano superiore e fondo in tecnopelle 05 latte. Tubi appendiabiti champagne opaco.

Here and on the previous page: Senzafine Cover wardrobe with leaf doors, Cover doors in fabric lino chiaro with mat champagne profiles and mat champagne Fitted handles. Structure and back panels in canvas beige melamine and side panels in fabric lino chiaro. Optional mat champagne support. Inner shelves in elm melamine with mat champagne front edge. Dressers with top in techno leather 05 latte, fronts in reflective fumé glass 5059, mat champagne Track handles and front edge of the top. Drawers' interior in ardesia melamine and bottom in techno leather 05 latte. Pocket-emptying accessories in champagne mat lacquered with top and bottom in techno leather 05 latte. Mat champagne hanging rails.





Qui e nella pagina successiva: armadio Senzafine Fitted apertura battente, ante Fitted in vetro trasparente riflettente 5000 con telaio e maniglie champagne opaco. Struttura e schienali in nobilitato canvas beige. Zoccolo opzionale champagne opaco. Cassettiera a vetrina con piano superiore in vetro fumè 3050, vassoio estraibile con frontale laccato opaco champagne e fondo in tecnopelle 06 nocciola. Cassetti inferiori con frontali in vetro riflettente fumè 5059, telaio e maniglia Track champagne opaco, fondo cassetto in tecnopelle 06 nocciola. Vassoi portaoggetti e portapantaloni in nobilitato canvas beige con maniglie Track champagne opaco. Tubi appendiabiti in tecnopelle 06 nocciola.

Here and on the next page: Senzafine Fitted wardrobe with leaf opening, Fitted doors in reflective transparent glass 5000 with mat champagne frame and handles. Structure and back panels in canvas beige melamine. Optional mat champagne support. Display case dresser with upper top in fumé glass 3050, pull-out tray with champagne mat lacquered front and bottom in techno leather 06 nocciola. Lower drawers with fronts in reflective fumé glass 5059, mat champagne frame and Track handle, drawer bottom in techno leather 06 nocciola. Storage trays and trouser holders in canvas beige melamine with mat champagne Track handles. Hanging rails in techno leather 06 nocciola.





A sinistra: dettaglio della cassettera a vetrina con piano superiore in vetro fumè 3050, vassoio estraibile con frontale laccato opaco champagne e fondo in tecnopelle 06 nocciola. Cassetti inferiori con frontali in vetro riflettente fumè 5059, telaio e maniglia Track champagne opaco, fondo cassetto in tecnopelle 06 nocciola. Sotto: dettaglio dell'anta Fitted in vetro trasparente riflettente 5000 con telaio e serratura opzionale champagne opaco.

On the left: detail of the display case dresser with upper top in fumé glass 3050, pull-out tray with champagne mat lacquered front and bottom in techno leather 06 nocciola. Lower drawers with fronts in reflective fumé glass 5059, mat champagne frame and Track handle, drawer bottom in techno leather 06 nocciola. Below: detail of the Fitted door in reflective transparent glass 5000 with mat champagne frame and optional lock.





Qui e nella pagina successiva: armadio Senzafine Plus apertura coplanare, ante Plus in laccato metallico 24 ottone e maniglie in brown nickel satinato. Al centro ante Ego apertura battente in vetro 2700 line e telaio laccato opaco 23 bronzo. Zoccolo opzionale champagne opaco. Struttura in canvas beige e schienali in nobilitato olmo. Ripiani in nobilitato olmo con bordo anteriore champagne opaco. Cassettiera a vetrina sospesa con piano superiore in vetro fumè 3050, vassoio estraibile con frontale laccato opaco champagne, fondo cassetto in tecnopelle 06 nocciola. Cassetti inferiori con frontali in nobilitato olmo, maniglia Step champagne opaco e tecnopelle 06 nocciola, fondo cassetti in tecnopelle 06 nocciola.

Here and on the next page: Senzafine Plus wardrobe with coplanar opening, Plus doors in metal lacquer 24 ottone and handles in brushed brown nickel. At the centre, Ego doors with leaf opening in glass 2700 line and mat lacquered frame 23 bronzo. Optional mat champagne plinth. Structure in canvas beige and back panels in elm melamine. Shelves in elm melamine with mat champagne front edge. Suspended display case dresser with upper top in fumé glass 3050, pull-out tray with champagne mat lacquered front, drawer bottom in techno leather 06 nocciola. Lower drawers with elm melamine fronts, mat champagne Step handle and techno leather 06 nocciola, drawers' bottom in techno leather 06 nocciola.





A sinistra: dettaglio della cassetiera a vetrina sospesa con piano superiore in vetro fumè 3050, vassoio estraibile con frontale laccato opaco champagne, fondo cassetto in tecnopelle 06 nocciola. Cassetti inferiori con frontali in nobilitato olmo, maniglia Step champagne opaco e tecnopelle 06 nocciola, fondo cassetti in tecnopelle 06 nocciola. Sotto: dettaglio dell'anta Plus in laccato metallico 24 ottone e maniglia in brown nickel satinato.

On the left: detail of the suspended display case dresser with upper top in fumé glass 3050, pull-out tray with champagne mat lacquered front, drawer bottom in techno leather 06 nocciola. Lower drawers with elm melamine fronts, mat champagne Step handle and techno leather 06 nocciola, drawers' bottom in techno leather 06 nocciola. Below: detail of the Plus door in metal lacquer 24 ottone and handle in brushed brown nickel.







Qui e nella pagina precedente: armadio Senzafine Plus apertura battente, ante Plus in laccato semilucido 89 roccia e maniglie champagne opaco. Fianchi laterali in laccato metallico 24 ottone. Struttura, schienali e attrezzatura interna in nobilitato canvas grigio.

Here and on the previous page: Senzafine Plus wardrobe with leaf doors, Plus doors in semi-glossy lacquered 89 roccia and mat champagne handles. Side panels in metal lacquer 24 ottone. Structure, back panels and internal equipment in canvas grigio melamine.



A sinistra: dettaglio del ripiano in vetro fumé 3050 con telaio ardesia opaco. Cassettiere con top in tecnopelle 06 nocciola, frontali in nobilitato canvas grigio, maniglie Step ardesia opaco e tecnopelle 06 nocciola. Interno cassetti in nobilitato ardesia e fondo in tecnopelle 06 nocciola. Accessori svuota tasche in laccato opaco ardesia con piano superiore e fondo in tecnopelle 06 nocciola. Sotto: dettaglio dell'anta Plus in laccato semilucido 89 roccia e maniglia integrata champagne opaco.

On the left: detail of the shelf in fumé glass 3050 with mat ardesia frame. Dressers with top in techno leather 06 nocciola, canvas grigio melamine fronts, mat ardesia Step handles and techno leather 06 nocciola. Drawers' interior in ardesia melamine and bottom in techno leather 06 nocciola. Pocket-emptying accessories in lacquered with upper top and bottom in techno leather 06 nocciola. Below: detail of the Plus door in semi-glossy lacquered 89 roccia and integrated mat champagne handle.







Nella pagina precedente e nella successiva: armadio Senzafine Cover apertura battente, ante Cover in vetro acidato 5323 bronzo con profili e maniglie Fitted ardesia opaco. Struttura, schienali e attrezzatura interna in nobilitato canvas beige. Tubi appendiabiti in tecnopelle 06 nocciola. Fianchi laterali in laccato opaco 02 ardesia e zoccolo opzionale ardesia opaco. In questa pagina: sanificatore d'aria opzionale in alluminio ardesia opaco, applicato al ripiano in nobilitato canvas beige. Il dispositivo di sanificazione, disponibile in ardesia opaco o champagne opaco, è integrato nel sistema elettrificato dell'armadio, con lunghezza pari al ripiano. Il bordo anteriore del ripiano è provvisto di tasti di comando e luce led; telecomando in dotazione.

On the previous and next page: Senzafine Cover wardrobe with leaf doors, Cover doors in etched glass 5323 bronzo with mat ardesia profiles and Fitted handles. Structure, back panels, and inner equipment in canvas beige melamine. Hanging rails in techno leather 06 nocciola. Side panels in mat lacquered 02 ardesia and optional mat ardesia plinth. On this page: optional air sanitizer in mat ardesia aluminium, applied to the shelf in canvas beige melamine. The sanitizing device, available in mat ardesia or mat champagne, is integrated in the wardrobe's electrified system, with a length equal to the shelf. The front edge of the shelf has the control buttons and led light; remote control included.







maniglia Cover
Cover handle

COVER TECNOPELLE

Design R&D Poliform

Dati Tecnici

Anta Cover, spessore 25 mm, maniglia applicata Cover o Fitted.

Aperture: battente o complanare.

Finiture anta: rivestita in tecnopelle 4 colori con profilo in alluminio su 4 lati, finitura ardesia opaco o champagne opaco.

Finitura maniglia Cover: tecnopelle 4 colori.

Finitura maniglia Fitted: ardesia opaco o champagne opaco.

Technical data

Cover door, thickness 1", Cover or Fitted applied handle.

Opening: leaf or coplanar.

Door finishes: covered in 4 techno leather colours with aluminium profile on 4 sides, finish mat ardesia or mat champagne.

Cover handle finish: 4 techno leather colours.

Fitted handle finish: mat ardesia or mat champagne.



maniglia Fitted
Fitted handle

Larghezza colonne Unit widths

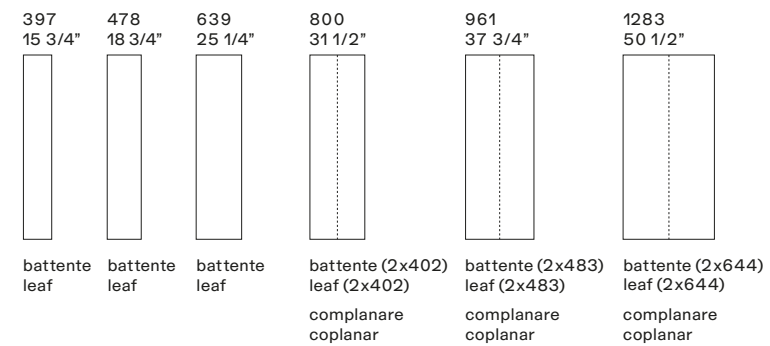

Altezza colonne Unit heights

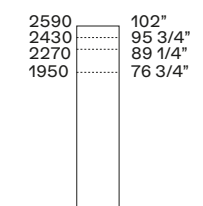

Complanare non disponibile nell'altezza 1950.
Coplanar door not available in height 76 3/4".



maniglia Fitted
Fitted handle

COVER TESSUTO

Design R&D Poliform

Dati Tecnici

Anta Cover, spessore 25 mm, maniglia applicata Fitted.

Aperture: battente o complanare.

Finiture anta: rivestita nella finitura tessuto lino chiaro o tessuto lino scuro con profilo in alluminio su 4 lati, finitura ardesia opaco o champagne opaco.

Finitura maniglia Fitted: ardesia opaco o champagne opaco.

Technical data

Cover door, thickness 1", Fitted applied handle.

Opening: leaf or coplanar.

Door finishes: covered in fabric lino chiaro or fabric lino scuro with aluminium profile on 4 sides, finish mat ardesia or mat champagne.

Fitted handle finish: mat ardesia or mat champagne.

Larghezza colonne Unit widths

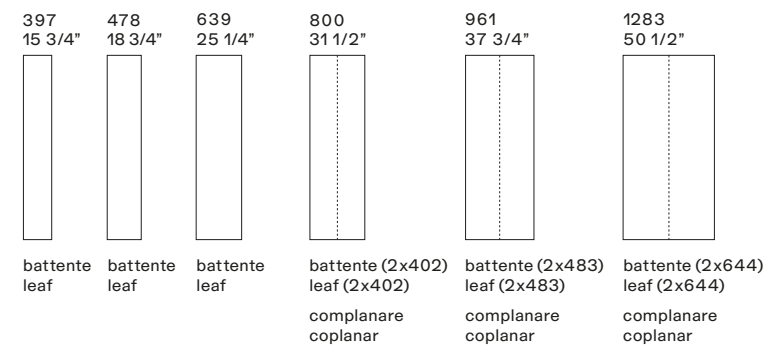

Altezza colonne Unit heights

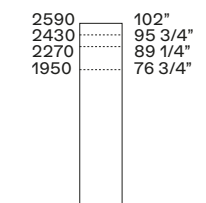

Complanare non disponibile nell'altezza 1950.
Coplanar door not available in height 76 3/4".

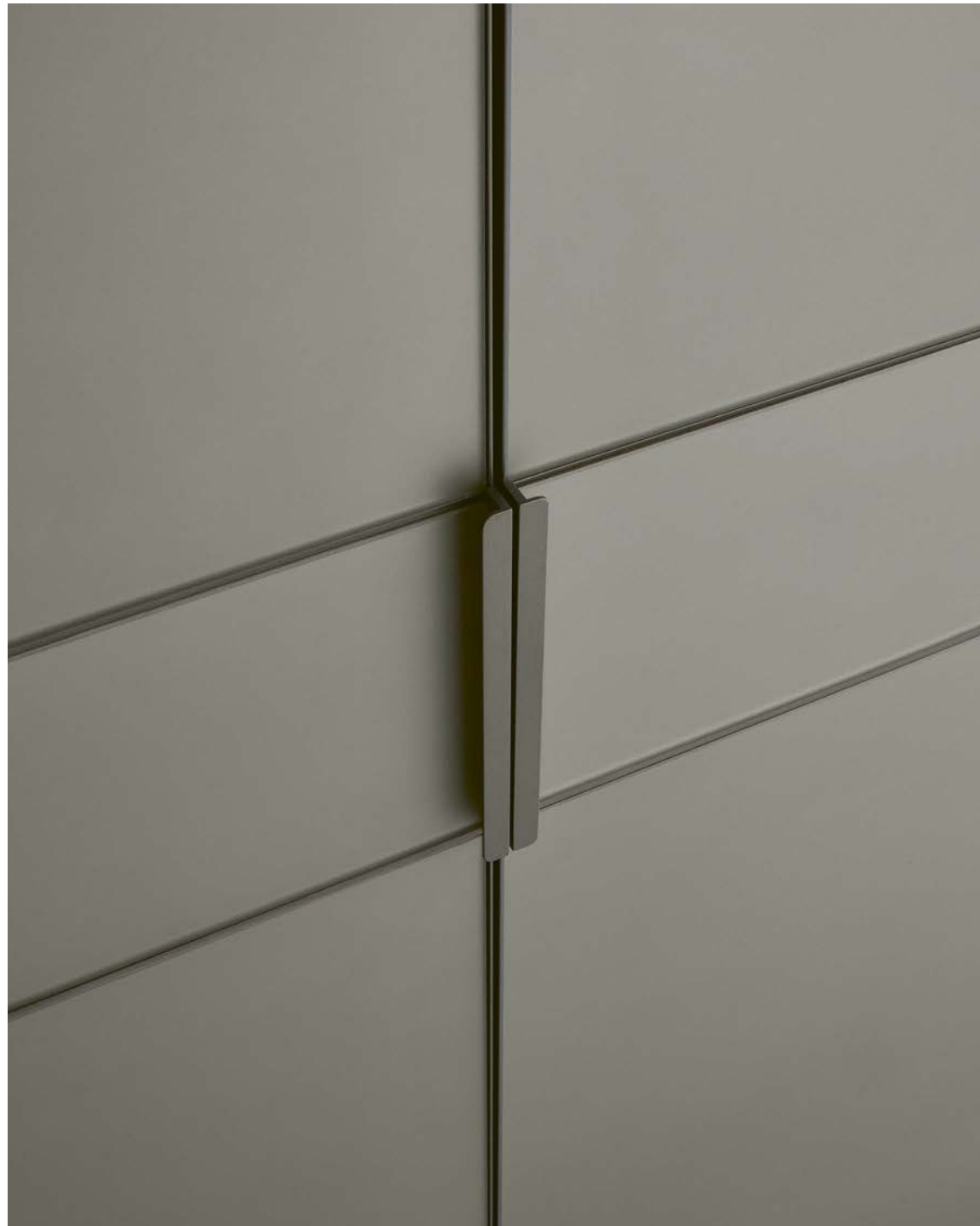

maniglia Fitted
Fitted handle

COVER VETRO

Design R&D Poliform

Dati Tecnici

Anta Cover, spessore 25 mm, maniglia applicata Fitted.

Aperture: battente o complanare.

Finiture anta: vetro acidato nella finitura 5325 titanio, 5323 bronzo o 5380 acciaio, con profilo in alluminio su 4 lati, finitura ardesia opaco o champagne opaco. La versione battente prevede l'interno anta nella stessa finitura del profilo (ardesia o champagne).

Finitura maniglia Fitted: ardesia opaco o champagne opaco.

Technical data

Cover door, thickness 1", Fitted applied handle.

Opening: leaf or coplanar.

Door finishes: etched glass in the finish 5325 titanio, 5323 bronzo o 5380 acciaio, with aluminium profile on 4 sides, finish mat ardesia or mat champagne. The leaf door version has the door interior in the same finish of the profile (ardesia or champagne).

Fitted handle finish: mat ardesia or mat champagne.

Larghezza colonne Unit widths

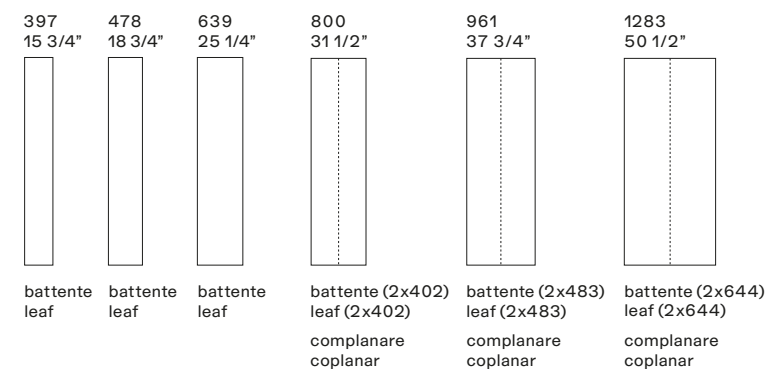

Altezza colonne Unit heights

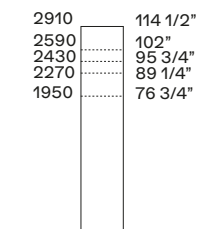

Complanare non disponibile nell'altezza 1950 e 2910.

Coplanar door not available in height 76 3/4" and 114 1/2".

UBIK

Il sistema Ubik si presenta rinnovato dopo il restyling. L'eleganza delle nuove finiture rende ancora più raffinata la cabina armadio, trasformandola in un ambiente intimo e personale.

The Ubik system is renewed after the restyling. The elegance of the new finishes makes the walk-in closet even more refined, transforming it into an intimate and personal environment.







Qui, nelle pagine precedenti e nella successiva: cabina armadio Ubik, pannellatura, basamento e ripiano superiore in nobilitato canvas grigio. Zoccolo opzionale champagne opaco. Ripiani in vetro fumè 3050 e tecnopelle 06 nocciola con telaio champagne opaco. Cassettiere a vetrina sospese con piano superiore in vetro fumè 3050, vassoio estraibile con frontale champagne opaco, fondo cassetti tecnopelle 06 nocciola. Cassetti inferiori con frontali in vetro riflettente fumè 5059, maniglia Track champagne opaco e fondo cassetti in tecnopelle 06 nocciola. Tubi appendiabiti champagne opaco e in tecnopelle 06 nocciola.

Here, on the previous pages and the next one: Ubik walk-in closet, panelling, base, and upper shelf in canvas grigio melamine. Optional mat champagne plinth. Shelves in fumé glass 3050 and techno leather 06 nocciola with mat champagne frame. Suspended display case drawers with upper top in fumé glass 3050, pull-out tray with mat champagne front, drawers' bottom in techno leather 06 nocciola. Lower drawers with fronts in reflective fumé glass 5059, mat champagne Track handle and drawers' bottom in techno leather 06 nocciola. Mat champagne and techno leather 06 nocciola hanging rails.





CIRCLE



La perfezione geometrica del cerchio incontra l'eleganza della cornice in cuoio: nasce così Circle, uno specchio da parete che arreda con semplicità ogni ambiente.

Where the geometric perfection of the circle meets the elegance of the frame in hide: Circle is conceived as a wall mirror which furnishes any environment with its simplicity.





CIRCLE
Design R&D Poliform

Dati tecnici
Specchio da parete con cornice in metallo rivestita in cuoio nei colori 02 nero e 26 invecchiato. Colore specchio 4000 bianco.

Technical data
Wall mirror with metal frame covered in hide in the colours 02 nero e 26 invecchiato. Mirror finish 4000 white.

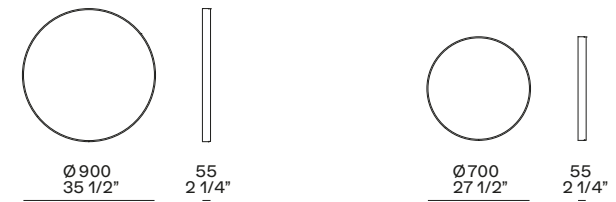

Sopra: specchio Circle con cornice in cuoio 02 nero. Nella pagina precedente: specchio Circle con cornice in cuoio 26 invecchiato.

Above: Circle mirror with frame in hide 02 nero. Previous page: Circle mirror with frame in hide 26 invecchiato.



TRATTO

A completare gli ambienti, il nuovo tappeto Tratto. Realizzato in un blend di lana himalayana, morbida al tatto, e seta di bambù, che lo rende cangiante, è caratterizzato dai motivi geometrici e disponibile in tre combinazioni di colore.

To complete the environments, the new Tratto rug. Made of a blend of Himalayan wool, soft to the touch, and bamboo silk, which makes it iridescent, it is characterized by geometric patterns and available in three colour combinations.







TRATTO

Design R&D Poliform

Dati tecnici

Prodotto a mano con tecnica handloom.
 Trama in cotone, vello in lana himalayana e seta di bambù.
 Dimensioni mm: rettangolare 1700×2400
 2300×3000 - 3000×4000
 quadrato 3000×3000.

Technical data

Handmade with the handloom technique.
 Cotton weave, fleece in Hymalayan wool and bamboo silk.
 Dimensions inches: rectangular 67"x94 1/2"
 90 1/2"x118" - 118"x157 1/2"
 square 118"x118".

ruggine

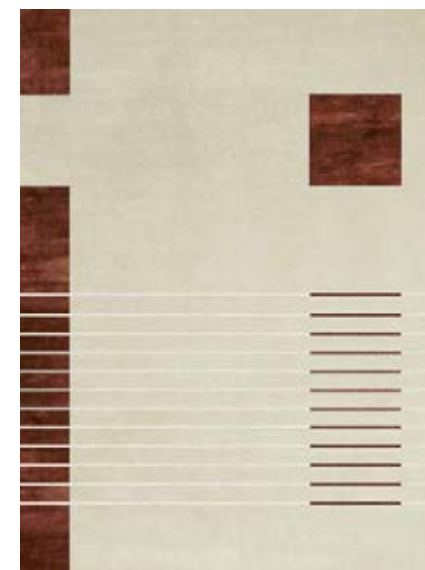

carbone

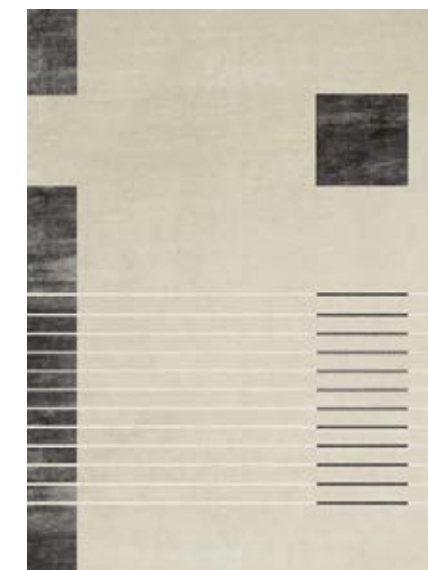

tortora



FINITURE SISTEMA GIORNO CODE
CODE DAY SYSTEM FINISHINGS

Boiserie - pannelli
Wall panelling - panels



27 colori - colours
laccato opaco
mat lacquered



3 colori - colours
laccato metallico
metal lacquered



noce gold
walnut gold ●



olmo nero
black elm



lino chiaro
tessuto
fabric ●

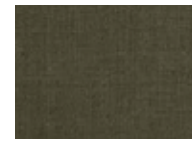

lino scuro
tessuto
fabric ●

Mensole
Shelves



27 colori - colours
laccato opaco
mat lacquered



3 colori - colours
laccato metallico
metal lacquered

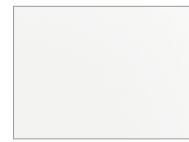

5000
trasparente riflettente
transparent reflecting



5059
fumé riflettente
fumé reflecting

Boiserie e mensole - profili
Wall panelling and shelves - profiles

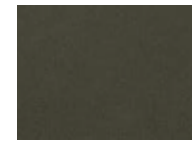

ardesia opaco
mat ardesia ●



champagne opaco
mat champagne ●

Contenitori bassi - struttura interna
Low storage units - inner structure



nobilitato ardesia
ardesia melamine

Contenitori bassi - frontali e fianchi
Low storage units - fronts and sides



27 colori - colours
laccato opaco
mat lacquered



10 colori - colours ●
laccato semilucido
semi-glossy lacquered



3 colori - colours
laccato metallico
metal lacquered

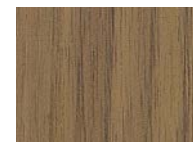

noce gold
walnut gold ●



olmo nero
black elm

Contenitori bassi - top
Low storage units - top



27 colori - colours
laccato opaco
mat lacquered



10 colori - colours ●
laccato semilucido
semi-glossy lacquered



3 colori - colours
laccato metallico
metal lacquered

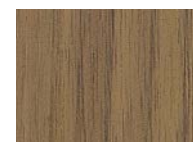

noce gold
walnut gold ●



olmo nero
black elm



zecevo
marmo levigato
mat marble ●



bianco carrara
marmo levigato e
lucido - mat and
glossy marble



calacatta oro
marmo levigato e
lucido - mat and
glossy marble



grigio stardust
marmo levigato e
lucido - mat and
glossy marble



emperador dark
marmo levigato e
lucido - mat and
glossy marble



sahara noir finitura
poliestere - polyester
finish
marmo levigato e
lucido - mat and
glossy marble



noir saint laurent
marmo lucido
glossy marble

Contenitori alti e pensili - struttura interna
Tall storage units and hanging units - inner structure



27 colori - colours
laccato opaco
mat lacquered



noce gold
walnut gold ●



olmo nero
black elm



27 colori - colours
laccato opaco
mat lacquered

Contenitori alti, pensili, portali, vani a giorno e bacheche - schienali
Tall storage units, hanging units, portals, open storage units and display cases - backs



27 colori - colours
laccato opaco
mat lacquered



3 colori - colours
laccato metallico
metal lacquered



noce gold
walnut gold ●



olmo nero
black elm



lino chiaro
tessuto
fabric ●

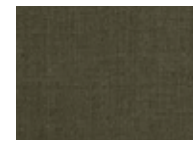

lino scuro
tessuto
fabric ●

Contenitori alti e pensili - ante legno
Tall storage units and hanging storage units - wooden doors



27 colori - colours
laccato opaco
mat lacquered



10 colori - colours ●
laccato semilucido
semi-glossy lacquered



3 colori - colours
laccato metallico
metal lacquered

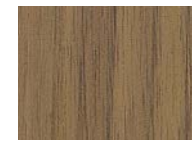

noce gold
walnut gold ●



olmo nero
black elm

Contenitori alti e pensili - ante vetro
Tall storage units and hanging units - glass doors

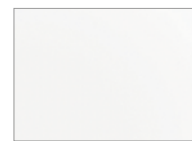

5000
trasparente riflettente
transparent reflecting

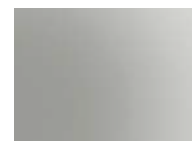

5059
fumé riflettente
fumé reflecting



ardesia opaco
mat ardesia ●



champagne opaco
mat champagne ●

Mensoloni sospesi
Suspended thick shelves



27 colori - colours
laccato opaco
mat lacquered



10 colori - colours ●
laccato semilucido
semi-glossy lacquered



3 colori - colours
laccato metallico
metal lacquered

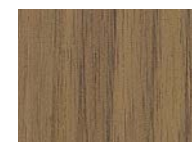

noce gold
walnut gold ●



olmo nero
black elm

Portali, vani a giorno e bacheche - struttura interna
Portals, open storage units and display cases - inner structure

● news

FINITURE MADIE CODE
CODE SIDEBORD FINISHINGS

Contenitori bassi e vani a giorno - struttura interna
Low storage units and open units - inner structure



27 colori - colours
laccato opaco
mat lacquered

Contenitori alti - struttura interna
Tall storage units - inner structure



27 colori - colours
laccato opaco
mat lacquered



noce gold
walnut gold ●



olmo nero
black elm

Contenitori alti e vani a giorno - schienali
Tall storage units and open units - backs



27 colori - colours
laccato opaco
mat lacquered



3 colori - colours
laccato metallico
metal lacquered

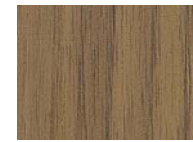

noce gold
walnut gold ●



olmo nero
black elm



lino chiaro
tessuto
fabric ●

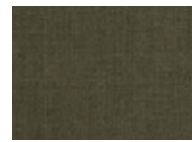

lino scuro
tessuto
fabric ●



4000
specchio bianco
white mirror ■



4051
specchio bronzato
bronzed mirror ■

■ Solo per vani a giorno
Only for open units

Frontali, fianchi e retro schienale
Fronts, sides and rear-back panel



27 colori - colours
laccato opaco
mat lacquered



10 colori - colours ●
laccato semilucido
semi-glossy lacquered



3 colori - colours
laccato metallico
metal lacquered

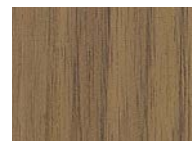

noce gold
walnut gold ●



olmo nero
black elm

Contenitori alti - ante vetro
Tall storage units - glass doors

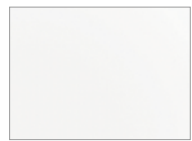

5000
trasparente riflettente
transparent reflecting

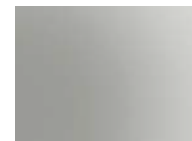

5059
fumé riflettente
fumé reflecting

Telaio ante vetro e basamenti
Glass doors frame and base



ardesia opaco ●
mat ardesia

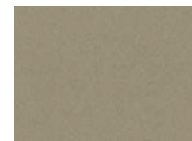

champagne opaco ●
mat champagne

Top di finitura
Finishing top



27 colori - colours
laccato opaco
mat lacquered



10 colori - colours ●
laccato semilucido
semi-glossy lacquered



3 colori - colours
laccato metallico
metal lacquered



noce gold ●
walnut gold



olmo nero
black elm



zecevo
marmo levigato ●
mat marble



bianco carrara
marmo levigato e
lucido - mat and
glossy marble



calacatta oro
marmo levigato e
lucido - mat and
glossy marble

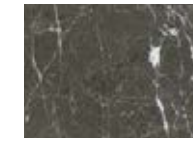

grigio stardust
marmo levigato e
lucido - mat and
glossy marble



emperador dark
marmo levigato e
lucido - mat and
glossy marble



sahara noir finitura
poliestere - polyester
finish
marmo levigato e
lucido - mat and
glossy marble



noir saint laurent
marmo lucido
glossy marble

FINITURE ACCESSORI OPZIONALI PER SISTEMA E MADIE CODE
OPTIONAL ACCESSORIES FINISHINGS FOR CODE SYSTEM AND SIDEBOARDS

Cassettini opzionali per contenitori alti
Optional drawers for tall storage units



27 colori - colours
laccato opaco
mat lacquered

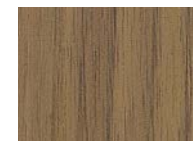

noce gold ●
walnut gold

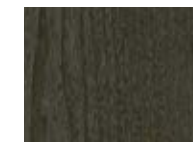

olmo nero
black elm



23 bronzo
laccato metallico
metal lacquered

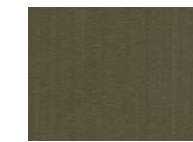

24 ottone
laccato metallico
metal lacquered



25 titanio
laccato metallico
metal lacquered

Fondo opzionale cassetti
Optional drawer bottom



05 latte
tecnopelle
techno leather



01 elefante
tecnopelle
techno leather



02 moro
tecnopelle
techno leather

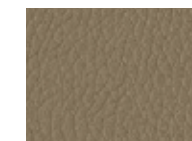

06 nocciola ●
tecnopelle
techno leather

FINITURE UBIK
UBIK FINISHINGS

**Pannellatura
Panelling**



canvas beige
nobilitato - melamine



canvas grigio
nobilitato - melamine

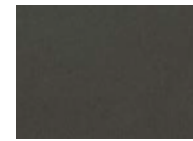

ardesia
nobilitato - melamine



olmo - elm
nobilitato - melamine



noce c. - walnut c.
nobilitato - melamine



rovere spessart
spessart oak
nobilitato - melamine



rovere cenere
cenere oak
nobilitato - melamine



roller latte
metacrilato
methacrylate



roller ardesia
metacrilato
methacrylate



skin
nobilitato - melamine
* 27 colori laccato opaco
a campionario e
4 colori tecnopelle
27 mat lacquered colours
as for sample book and
4 techno leather colours

**Pannellatura vetro
Glass panelling**



2201 bianco extrachiaro
bianco extralight
vetro lucido
glossy glass



2273 ghiaccio
vetro lucido
glossy glass



1235 canapa
vetro lucido
glossy glass



1264 arena
vetro lucido
glossy glass



1204 grafite
vetro lucido
glossy glass



1203 nero
vetro lucido
glossy glass



4000 specchio bianco
white mirror



5325 titanio
vetro acidato
etched glass



5323 bronzo
vetro acidato
etched glass



5380 acciaio
vetro acidato
etched glass

**Attrezzatura
Equipment**



canvas beige
nobilitato - melamine



canvas grigio
nobilitato - melamine

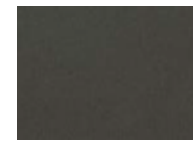

ardesia
nobilitato - melamine
escluso frontali cassetti
except drawers fronts



olmo - elm
nobilitato - melamine



noce c. - walnut c.
nobilitato - melamine



rovere spessart
spessart oak
nobilitato - melamine



rovere cenere
cenere oak
nobilitato - melamine

● news

**Basamenti, ripiani, cassetiere, attrezzature
Bases, shelves, chest of drawers, equipment**



canvas beige
nobilitato - melamine



canvas grigio
nobilitato - melamine

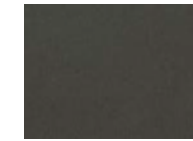

ardesia
nobilitato - melamine



olmo - elm
nobilitato - melamine



noce c. - walnut c.
nobilitato - melamine



rovere spessart
spessart oak
nobilitato - melamine



rovere cenere
cenere oak
nobilitato - melamine

**Frontale cassetti
Drawers front**



canvas beige
nobilitato - melamine



canvas grigio
nobilitato - melamine

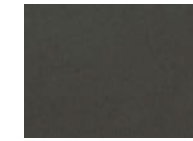

ardesia
nobilitato - melamine



roller latte
metacrilato
methacrylate



roller ardesia
metacrilato
methacrylate



5059
riflettente fumé
fumé reflecting



olmo - elm
nobilitato - melamine



noce c. - walnut c.
nobilitato - melamine



rovere spessart
spessart oak
nobilitato - melamine



rovere cenere
cenere oak
nobilitato - melamine

**Ripiani tecnopelle
Techno leather shelves**



05 latte
tecnopelle
techno leather



01 elefante
tecnopelle
techno leather



02 moro
tecnopelle
techno leather



06 nocciola
tecnopelle
techno leather

**Ripiani vetro
Glass shelves**



3050 fumé

**Parti metalliche, ferramenta
Metal parts, hardware**



ardesia opaco
mat ardesia

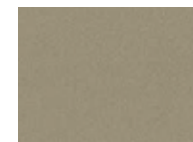

champagne opaco
mat champagne

● news

FINITURE SENZAFINE
SENZAFINE FINISHINGS

Struttura
Structure



canvas beige
nobilitato - melamine



canvas grigio
nobilitato - melamine

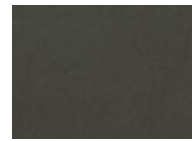

ardesia
nobilitato - melamine



olmo - elm
nobilitato - melamine



noce c. - walnut c.
nobilitato - melamine



rovere spessart
spessart oak
nobilitato - melamine



rovere cenere
cenere oak
nobilitato - melamine

Schienale
Back



canvas beige
nobilitato - melamine



canvas grigio
nobilitato - melamine

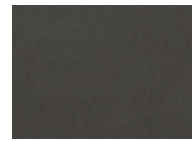

ardesia
nobilitato - melamine



olmo - elm
nobilitato - melamine



noce c. - walnut c.
nobilitato - melamine



rovere spessart
spessart oak
nobilitato - melamine



rovere cenere
cenere oak
nobilitato - melamine



roller latte
metacrilato
methacrylate



roller ardesia
metacrilato
methacrylate



skin
nobilitato - melamine
31 colori laccato opaco
31 mat lacquered
colours

* 27 colori laccato opaco
a campionario e
4 colori tecnopelle
27 mat lacquered colours
as for sample book and
4 techno leather colours

Schienale vetro
Glass back



2700 line

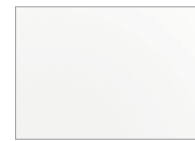

1000
trasparente
transparent



3050 fumé

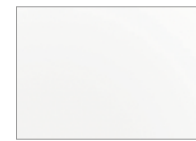

5000
trasparente riflettente
transparent reflecting



5051
bronzato riflettente
bronzed reflecting

Fianco vetro
Glass side



2700 line

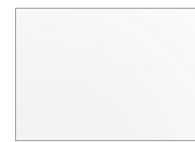

1000
trasparente
transparent

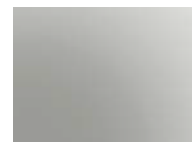

3050 fumé

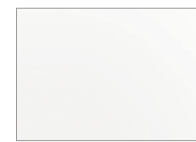

5000
trasparente riflettente
transparent reflecting



5051
bronzato riflettente
bronzed reflecting

● news

Attrezzatura
Equipment



canvas beige
nobilitato - melamine



canvas grigio
nobilitato - melamine

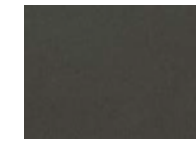

ardesia
nobilitato - melamine



olmo - elm
nobilitato - melamine



noce c. - walnut c.
nobilitato - melamine



rovere spessart
spessart oak
nobilitato - melamine



rovere cenere
cenere oak
nobilitato - melamine

Ripiani tecnopelle
Techno leather shelves



05 latte
tecnopelle
techno leather



01 elefante
tecnopelle
techno leather

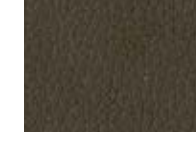

02 moro
tecnopelle
techno leather

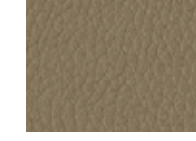

06 nocciola
tecnopelle
techno leather

Ripiani vetro
Glass shelves

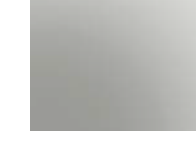

3050 fumé

Frontale cassette
Drawers front



canvas beige
nobilitato - melamine

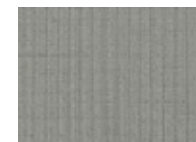

canvas grigio
nobilitato - melamine

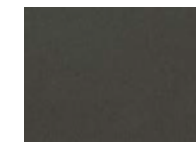

ardesia
nobilitato - melamine



roller latte
metacrilato
methacrylate



roller ardesia
metacrilato
methacrylate

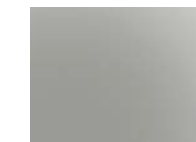

5059
riflettente fumé
fumé reflecting



olmo - elm
nobilitato - melamine



noce c. - walnut c.
nobilitato - melamine



rovere spessart
spessart oak
nobilitato - melamine



rovere cenere
cenere oak
nobilitato - melamine

Parti metalliche, ferramenta
Metal parts, hardware

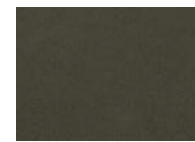

ardesia opaco
mat ardesia



champagne opaco
mat champagne

● news

FINITURE NUOVE ANTE SENZAFINE
SENZAFINE NEW DOORS FINISHINGS

Anta Cover tecnopelle
Tecno leather Cover door



Anta Cover tessuto ●
Fabric Cover door

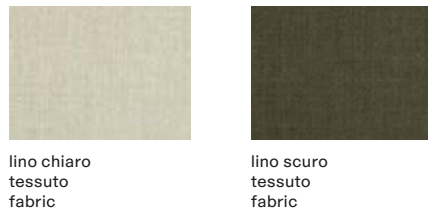

Anta Cover vetro ●
Glass Cover door

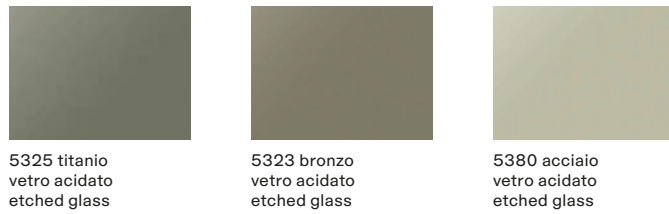

● news

FINITURE
FINISHINGS

Laccato opaco
Mat lacquered



Laccato semilucido ●
Semi-glossy lacquered

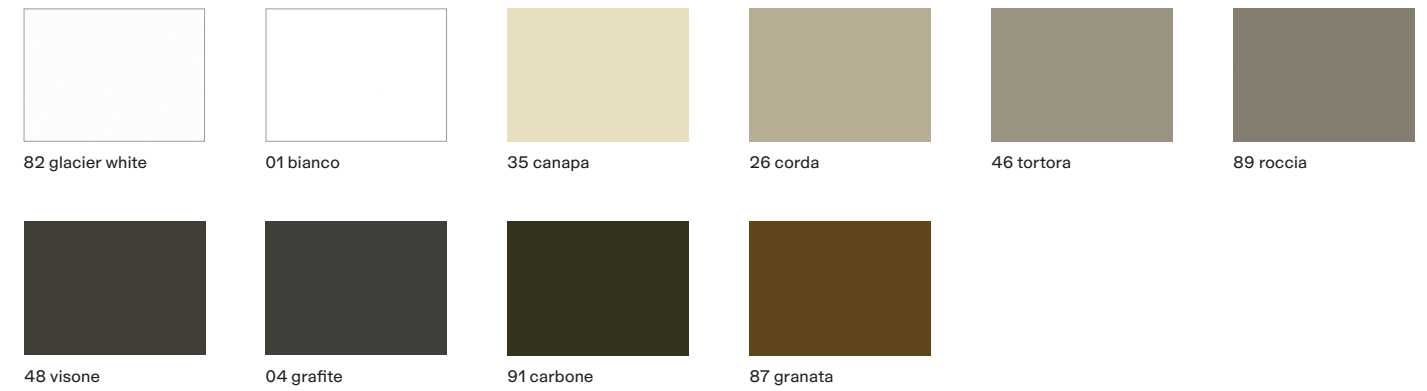

Laccato Semilucido disponibile solo per sistema Senzafine e sistema Code.
Semi-glossy lacquered available only for Senzafine system and Code system.

● news

FINITURE FINISHINGS

Laccato lucido Glossy lacquered



82 glacier white



01 bianco



35 canapa



26 corda



88 castoro



46 tortora



60 ghiaccio



64 arena



48 visone



49 moka



04 grafite



91 carbone



78 ferro



83 ocra



85 caramello



92 vischio



87 granata



86 danubio

Laccato antigraffio Antiscratch lacquered



01 bianco



35 canapa



04 grafite



91 carbone

Laccato metallico Metal lacquered



23 bronzo



24 ottone



25 titanio

Essenza Wood



noce gold
walnut gold

Marmo levigato Mat marble



zecevo

● news

TESSUTI FABRICS

Caleo ● fabric cat. B



01 bianco



02 sabbia



03 canapa



04 tortora

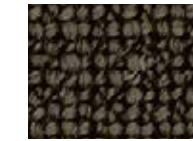

05 moka

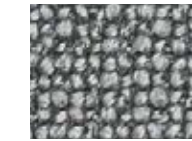

06 argento



07 acciaio

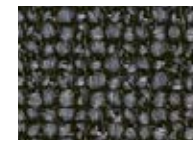

08 ferro



09 grafite

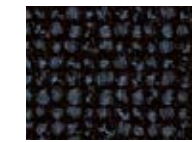

10 notte



11 navy



12 senape

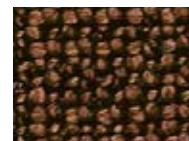

13 ruggine



14 viola

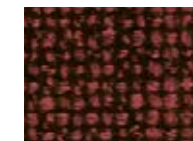

15 bordeaux

Eraclea ● fabric cat. B



01 ghiaccio



02 sabbia



03 tortora



04 cenere



05 platino



06 argento



07 acciaio

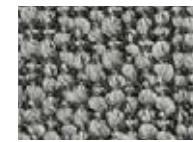

08 piombo



09 ferro



10 notte



11 bordeaux



12 ruggine

Antea ● fabric cat. D

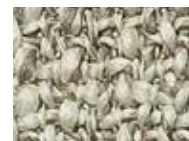

01 sabbia



04 canapa



03 visone



07 polvere



06 platino



08 cenere



09 piombo



10 grafite



11 notte



05 terra di siena



12 terracotta



13 senape



14 foresta

● news

TESSUTI
FABRICS

**Micene •
fabric cat. D**



01 ghiaccio



02 acciaio



03 sabbia



04 corda



05 visone



06 peltro



07 notte



08 argilla



10 bordeaux

**Arcadia •
fabric cat. E**



01 avorio



02 sabbia



03 canapa



04 senape



05 bronzo



06 tortora



07 argento



08 ferro



09 grafite



10 notte



11 oliva



12 polvere

**Lero •
fabric cat. G**



01 ecrù



03 ferro

**Siro •
fabric cat. G**



01 bianco



02 lino



04 notte



05 ruggine

TESSUTI E PELLI
FABRICS AND LEATHERS

**Tebe •
fabric cat. G**



01 bianco



02 sabbia



03 tortora



04 cenere



05 acciaio



06 giada



07 oliva



08 notte



09 viola



10 rubino

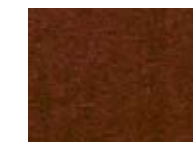

11 bruciato

**Silk •
leather cat. S**



01 crema



02 beige

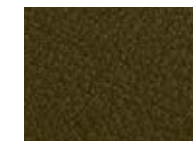

03 talpa

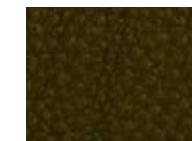

04 ebano

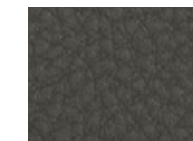

05 cemento



06 roccia



07 grafite



08 nero



09 notte



12 senape



13 oliva



11 cognac



10 terracotta

**Hairy •
leather**



bianco/nero



cappuccino

Poliform Spa

via Montesanto 28
Casella postale n. 1
22044 Inverigo (CO) Italy
t +39 031 6951
f +39 031 699444
info@poliform.it
poliform.it

Poliform realizza tutte le sue collezioni in Italia usando componenti e materie prime selezionate.

All the Poliform collections are manufactured 100% in Italy using top-class components and materials.

Poliform si riserva il diritto di apportare, senza preavviso, ogni modifica mirata al miglioramento funzionale e qualitativo dei propri prodotti. Testi e disegni presenti in questo stampato hanno scopo divulgativo: per ogni aspetto tecnico e dimensionale fare riferimento ai listini aziendali e relativi aggiornamenti. I campioni di colori e materiali hanno valore indicativo.

Poliform reserves the rights at all time to apply modifications for the functional or qualitative improvement of its products. Texts and drawings present in this brochure have a divulgative purpose: for every technical and dimensional aspect please refer to the company's price lists and their relative updatings. The colour and material samples have an indicative value.

Creative Direction

Apartamento Studios

Graphic Design

Apartamento Studios

Photography

F2 Fotografia

Still Life Photography

Silvia Orlandi

Interiors Styling

Poliform Lab

1st edition June 2019
cod. 110/R1/2019

Thanks to: A.G. Spalding&Bros, André Von Martens, Andrea Baumann, Artemide, Atlas Crafts, Atelier de Troupe, Atipico, Bertoni 1949, B&T Textilia, Elena Ghisellini, Flos, Guaxs, Gum Design, John Born, J.&L. Lobmeyr, Laboratorio Avallone, Magdalena Ponagajbo, maisonFire S.r.l., Michael Anastassiades, Michele Reginaldi, Nemo Lighting, Odem Atelier, Oluce S.r.l., Paola C., Santa&Cole, Sara Ricciardi, Sijle Nesdal, Schönbuch, Urus Mihic



2018 Adi Compasso D'oro
Career Award



ASSARREDO
FEDERLEGNOARREDO



